

# ISO-9001

 **成利有限公司**  
CHONG LIH METAL CO.,LTD

電纜線槽及配件 | CABLE DUCTS, RACEWAYS & ACCESSORIES

# 電纜線槽型式

## TABLE OF AVAILABLE CABLE DUCT

### 壹·通風型線槽分類表：(VENTILATED)

通風型直式電纜線槽 (VENTILATED STRAIGHT TYPE CABLE DUCT)	1~2
通風型水平 90° 線槽 (HORIZONTAL 90°)	3~4
通風型水平 T 型線槽 (HORIZONTAL TEE)	5~6
通風型水平 X 型線槽 (HORIZONTAL CROSS)	7~8
通風型 90° 垂直上升線槽 (INSIDE VERTICAL 90°)	9~10
通風型 90° 垂直下降線槽 (OUTSIDE VERTICAL 90°)	11~12
通風型垂直 T 型線槽 (VERTICAL TEE)	13~14
通風中心型大小線槽 (BOTH SIDES REDUCER)	15
通風左縮型線槽 (LEFT HAND REDUCER)	16
通風右縮型線槽 (RIGHT HAND REDUCER)	17

### 貳·密閉型線槽分類表：(SOLID BOTTOM)

密閉型直式電纜線槽 (SOLID BOTTOM STRAIGHT TYPE CABLE DUCT)	18~19
密閉型水平 90° 線槽 (HORIZONTAL 90°)	20~21
密閉型水平 T 型線槽 (HORIZONTAL TEE)	22~23
密閉型水平 X 型線槽 (HORIZONTAL CROSS)	24~25
密閉型 90° 垂直上升線槽 (INSIDE VERTICAL 90°)	26~27
密閉型 90° 垂直下降線槽 (OUTSIDE VERTICAL 90°)	28~29
密閉型垂直 T 型線槽 (VERTICAL TEE)	30~31
密閉中心型大小線槽 (BOTH SIDES REDUCER)	32
密閉左縮型線槽 (LEFT HAND REDUCER)	33
密閉右縮型線槽 (RIGHT HAND REDUCER)	34

### 參·蓋板分類表：(COVERS)

直式, 水平 90° 線槽蓋板 (STRAIGHT, HORIZONTAL 90° COVER)	35
水平 T 型, X 型線槽蓋板 (HORIZONTAL TEE, CROSS COVER)	36
90° 垂直上升, 垂直下降線槽蓋板 (INSIDE VERTICAL 90°, OUTSIDE VERTICAL 90° COVER)	37
中心型, 左縮型大小線槽蓋板 (BOTH SIDES REDUCER, LEFT HAND REDUCER COVER)	38
右縮型大小線槽蓋板 (RIGHT HAND REDUCER COVER)	39

### 肆·線槽配件分類表：(ACCESSORIES)

直式連接片 (STRAIGHT CONNECTOR)	40
配電盤連接片 (PANNEL SPLICE PLATE)	41
終端封板 (BLIND END COVER)	42
大小頭連接片 (REDUCER PLATE)	43
蓋板夾系列 (COVER CLAMP SERIES)	44
壁架系列 (WALL SUPPORT SERIES)	45
線槽固定片 (HOLD DOWN CLAMP)	46
線槽分隔板 (STRAIGHT SEPARATOR)	46
H 型終端護夾 (H SHAPE GAP PROTECTORS)	47

# 日光燈線槽型式

## FLUORESCENT LAMPS CABLE RACEWAY

### 陸 · (B 型)日光燈線槽分類表：(RACEWAY SYSTEM)

直式日光燈線槽 (STRAIGHT LENGTH CABLE RACEWAY)	54
水平 90° 日光燈線槽 (HORIZONTAL 90°)	54
水平 X 型日光燈線槽 (HORIZONTAL CROSS)	55
水平 T 型日光燈線槽 (HORIZONTAL TEE)	55
垂直上升 90° 日光燈線槽 (INSIDE VERTICAL 90°)	56
垂直下降 90° 日光燈線槽 (OUTSIDE VERTICAL 90°)	56
日光燈線槽連接片 (STRAIGHT CONNECTOR)	57
配電盤連接片 (PANNEL SPLICE PLATE)	58
終端封板 (BLIND END COVER)	59

### 柒 · (C 型)日光燈線槽分類表：(RACEWAY SYSTEM)

直式日光燈線槽 (STRAIGHT LENGTH CABLE RACEWAY)	60
水平 90° 日光燈線槽 (HORIZONTAL 90°)	60
水平 X 型日光燈線槽 (HORIZONTAL CROSS)	61
水平 T 型日光燈線槽 (HORIZONTAL TEE)	61
垂直上升 90° 日光燈線槽 (INSIDE VERTICAL 90°)	62
垂直下降 90° 日光燈線槽 (OUTSIDE VERTICAL 90°)	62
日光燈線槽連接片 (STRAIGHT CONNECTOR)	63
配電盤連接片 (PANNEL SPLICE PLATE)	64
終端封板 (BLIND END COVER)	65
門型吊架 (RACEWAY HANGER)	66

# 電纜線槽型號說明表

## (HOW TO ORDER)

例如：S V A 1 S H (T)  
 材 型 線 線 線 表 線  
 質 式 槽 槽 槽 面 槽  
 ① ② ③ ④ ⑤ ⑥ ⑦  
 質 式 高 寬 角 處 厚  
 ① ② ③ ④ ⑤ ⑥ ⑦

代號說明：

材 質	A：鋁 S：熱軋鐵板 (4)：不銹鋼 304 (6)：不銹鋼 316 G：鍍鋅鐵板
型 式	L：梯型線架 D：密閉型線槽 V：通風型線槽 W：底板加強型線槽
邊槽高度	A：60H B：80H C：100H D：120H E：150H F：200H G：250H H：300H
線槽寬度	1：100W 2：200W 3：300W 4：400W 5：500W 6：600W 7：700W 8：800W 9：900W 0：1000W
線槽角度	S：直式 HL：水平接頭 HT：水平三通接頭 HX：水平四通接頭 IV：垂直上升接頭 OV：垂直下降接頭 VT：垂直三通接頭 RC：中心型大小接頭 RL：左縮型大小接頭 RR：右縮型大小接頭
表面處理	A：陽極處理 E：電著塗裝 H：熱浸鍍鋅 P：靜電粉體塗裝
邊槽厚度	標準厚度(T)：1.6mm 2mm 2.6mm

ILLUSTRATION：

①MATERIAL	A：ALUMINUM S：HOT ROLL STEEL SHEET (4)：STAINLESS STEEL304 (6)：STAINLESS STEEL316 G：GALVANIZED STEEL SHEET
②TYPE	L：LADDER TYPE D：SOLID BOTTOM TYPE V：VENTILATED TYPE W：CORRUGATED TYPE
③HEIGHT OF SIDE RAIL	A：60H B：80H C：100H D：120H E：150H F：200H G：250H H：300H
④WIDTH	1：100W 2：200W 3：300W 4：400W 5：500W 6：600W 7：700W 8：800W 9：900W 0：1000W
⑤STRAIGHT TRAY OR ELBOWS	S：STRAIGHT HL：HORIZONTAL ELBOW HT：HORIZONTAL TEE HX：HORIZONTAL CROSS IV：INSIDE VERTICAL ELBOW OV：OUTSIDE VERTICAL ELBOW VT：VERTICAL TEE RC：BOTH SIDES RR：LEFT HAND RL：RIGHT HAND
⑥FINISHES	A：ANODIC OXIDATION E：ELECTORDEPOSITED COATING AFTER ANODIC OXIDATION H：HOT DIP GALVANIZING AFTER FORMING P：POWDER COATING
⑦THICKNESS	(T)：1.6mm 2mm 2.6mm

# 通風型直式電纜線槽

## (VENTILATED STRAIGHT LENGTH CABLE DUCT)

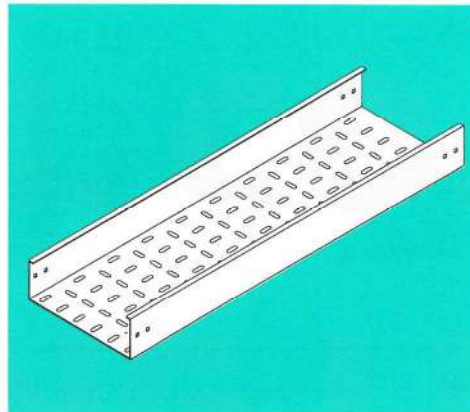

材 質：1.鋁合金 AA5052H32 或 AA1050H14 2.熱軋鐵板(JIS G3131)  
 3.鍍鋅鐵板(JIS 3302) 4.不銹鋼(SUS304) (SUS316)  
 表面處理：1.(鋁)陽極處理(10 $\mu$ ) 2.電著塗裝(17 $\mu$ )  
 3.(鐵)熱浸鍍鋅 (350g/m<sup>2</sup>) 4.靜電粉體塗裝(50 $\mu$ )  
 ※其他特殊規格亦可接受訂購

MATERIAL：1.ALUMINUM ALLOY AA5052H32 OR AA1050H14  
 2.HOT ROLL STEEL SHEET (JIS G3131)  
 3.GALVANIZED STEEL SHEET (JIS 3302)  
 4.STAINLESS STEEL (SUS304).OR (SUS316)

F I N I S H：1.ANODIC OXIDATION (10 $\mu$ )  
 2.ELECTRODEPOSITING COATING AFTER ANODIC OXIDATION (17 $\mu$ )  
 3.HOT DIP GALVANIZED AFTER FABRICATION (350g/m<sup>2</sup>)  
 4.POWDER COATING (50 $\mu$ )

※OTHER SIZES(WIDTHS) CAN BE ORDERED

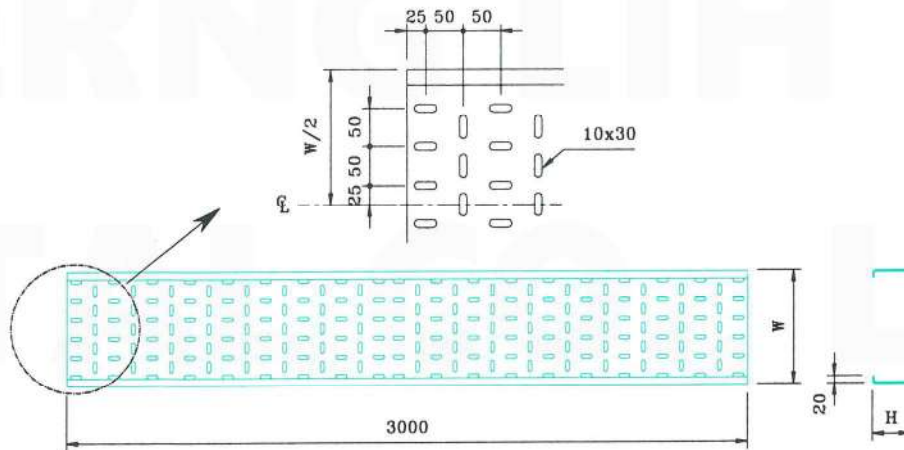

邊槽高度 60H 系列 (60mm HEIGHT SERIES) 厚度(T)=1.6mm or 2mm

(Units:mm)

邊槽各部尺寸圖	型 號 CAT NO	線槽寬度 W	邊槽高度 H	總 長 L
	SVA1SH(T)	100	60	3000
	SVA2SH(T)	200		
	SVA3SH(T)	300		
	SVA4SH(T)	400		
	SVA5SH(T)	500		
	SVA6SH(T)	600		
	SVA7SH(T)	700		
	SVA8SH(T)	800		
	SVA9SH(T)	900		
	SVA0SH(T)	1000		

邊槽高度 80H 系列 (80mm HEIGHT SERIES) 厚度(T)=1.6mm or 2mm

(Units:mm)

邊槽各部尺寸圖	型號 CAT.NO	線槽寬度 W	邊槽高度 H	總長 L
	SVB1SH(T)	100	80	3000
	SVB2SH(T)	200		
	SVB3SH(T)	300		
	SVB4SH(T)	400		
	SVB5SH(T)	500		
	SVB6SH(T)	600		
	SVB7SH(T)	700		
	SVB8SH(T)	800		
	SVB9SH(T)	900		
	SVB0SH(T)	1000		

邊槽高度 100H 系列 (100mm HEIGHT SERIES) 厚度(T)=1.6mm or 2mm

(Units:mm)

邊槽各部尺寸圖	型號 CAT.NO	線槽寬度 W	邊槽高度 H	總長 L
	SVC1SH(T)	100	100	3000
	SVC2SH(T)	200		
	SVC3SH(T)	300		
	SVC4SH(T)	400		
	SVC5SH(T)	500		
	SVC6SH(T)	600		
	SVC7SH(T)	700		
	SVC8SH(T)	800		
	SVC9SH(T)	900		
	SVC0SH(T)	1000		

邊槽高度 120H 系列 (120mm HEIGHT SERIES) 厚度(T)=1.6mm or 2mm

(Units:mm)

邊槽各部尺寸圖	型號 CAT.NO	線槽寬度 W	邊槽高度 H	總長 L
	SVD1SH(T)	100	120	3000
	SVD2SH(T)	200		
	SVD3SH(T)	300		
	SVD4SH(T)	400		
	SVD5SH(T)	500		
	SVD6SH(T)	600		
	SVD7SH(T)	700		
	SVD8SH(T)	800		
	SVD9SH(T)	900		
	SVD0SH(T)	1000		

邊槽高度 150H 系列 (150mm HEIGHT SERIES) 厚度(T)=2mm or 2.6mm

(Units:mm)

邊槽各部尺寸圖	型號 CAT.NO	線槽寬度 W	邊槽高度 H	總長 L
	SVE1SH(T)	100	150	3000
	SVE2SH(T)	200		
	SVE3SH(T)	300		
	SVE4SH(T)	400		
	SVE5SH(T)	500		
	SVE6SH(T)	600		
	SVE7SH(T)	700		
	SVE8SH(T)	800		
	SVE9SH(T)	900		
	SVE0SH(T)	1000		

# 通風型水平 90° 線槽 (HORIZONTAL 90°)

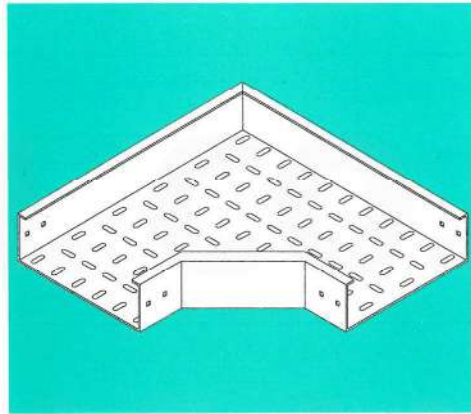

材 質：1.鋁合金 AA5052H32 或 AA1050H14 2.熱軋鐵板(JIS G3131)  
 3.鍍鋅鐵板(JIS 3302) 4.不銹鋼(SUS304) (SUS316)  
 表面處理：1.(鉍)陽極處理(10 $\mu$ ) 2.電著塗裝(17 $\mu$ )  
 3.(鐵)熱浸鍍鋅 (350g/m<sup>2</sup>) 4.靜電粉體塗裝(50 $\mu$ )  
 ※其他特殊規格亦可接受訂購

MATERIAL : 1.ALUMINUM ALLOY AA5052H32 OR AA1050H14  
 2.HOT ROLL STEEL SHEET (JIS G3131)  
 3.GALVANIZED STEEL SHEET (JIS 3302)  
 4.STAINLESS STEEL (SUS304).OR (SUS316)

F I N I S H : 1.ANODIC OXIDATION ( 10  $\mu$  )  
 2.ELECTRODEPOSITING COATING AFTER ANODIC OXIDATION ( 17  $\mu$  )  
 3.HOT DIP GALVANIZED AFTER FABRICATION ( 350g/m<sup>2</sup> )  
 4.POWDER COATING ( 50  $\mu$  )

※OTHER SIZES(WIDTHS) CAN BE ORDERED

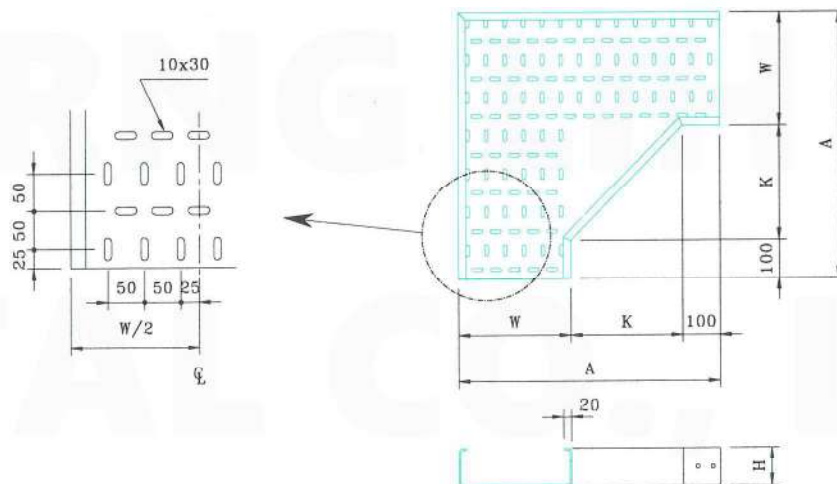

邊槽高度 60H 系列 (60mm HEIGHT SERIES) 厚度 (T)=1.6mm or 2mm

(Units:mm)

邊槽各部尺寸圖	型號 CAT NO	線槽寬度 W	邊槽高度 H	斜邊長度 K	總長 A
	SVA1HL9H(T)	100	60	150	350
	SVA2HL9H(T)	200			450
	SVA3HL9H(T)	300			550
	SVA4HL9H(T)	400		200	700
	SVA5HL9H(T)	500			800
	SVA6HL9H(T)	600			900
	SVA7HL9H(T)	700		300	1000
	SVA8HL9H(T)	800			1200
	SVA9HL9H(T)	900			1300
	SVA0HL9H(T)	1000		1400	

邊槽高度 80H 系列 (80mm HEIGHT SERIES) 厚度 (T)=1.6mm or 2mm

(Units:mm)

邊槽各部尺寸圖	型號 CAT.NO	線槽寬度 W	邊槽高度 H	斜邊長度 K	總長 A
	SVB1HL9H(T)	100	80	150	350
	SVB2HL9H(T)	200			450
	SVB3HL9H(T)	300			550
	SVB4HL9H(T)	400		200	700
	SVB5HL9H(T)	500			800
	SVB6HL9H(T)	600			900
	SVB7HL9H(T)	700		300	1000
	SVB8HL9H(T)	800			1200
	SVB9HL9H(T)	900			1300
	SVB0HL9H(T)	1000			1400

邊槽高度 100H 系列 (100mm HEIGHT SERIES) 厚度 (T)=1.6mm or 2mm

(Units:mm)

邊槽各部尺寸圖	型號 CAT.NO	線槽寬度 W	邊槽高度 H	斜邊長度 K	總長 A
	SVC1HL9H(T)	100	100	150	350
	SVC2HL9H(T)	200			450
	SVC3HL9H(T)	300			550
	SVC4HL9H(T)	400		200	700
	SVC5HL9H(T)	500			800
	SVC6HL9H(T)	600			900
	SVC7HL9H(T)	700		300	1000
	SVC8HL9H(T)	800			1200
	SVC9HL9H(T)	900			1300
	SVC0HL9H(T)	1000			1400

邊槽高度 120H 系列 (120mm HEIGHT SERIES) 厚度 (T)=1.6mm or 2mm

(Units:mm)

邊槽各部尺寸圖	型號 CAT.NO	線槽寬度 W	邊槽高度 H	斜邊長度 K	總長 A
	SVD1HL9H(T)	100	120	150	350
	SVD2HL9H(T)	200			450
	SVD3HL9H(T)	300			550
	SVD4HL9H(T)	400		200	700
	SVD5HL9H(T)	500			800
	SVD6HL9H(T)	600			900
	SVD7HL9H(T)	700		300	1000
	SVD8HL9H(T)	800			1200
	SVD9HL9H(T)	900			1300
	SVD0HL9H(T)	1000			1400

邊槽高度 150H 系列 (150mm HEIGHT SERIES) 厚度 (T)=2mm or 2.6mm

(Units:mm)

邊槽各部尺寸圖	型號 CAT.NO	線槽寬度 W	邊槽高度 H	斜邊長度 K	總長 A
	SVE1HL9H(T)	100	150	150	350
	SVE2HL9H(T)	200			450
	SVE3HL9H(T)	300			550
	SVE4HL9H(T)	400		200	700
	SVE5HL9H(T)	500			800
	SVE6HL9H(T)	600			900
	SVE7HL9H(T)	700		300	1000
	SVE8HL9H(T)	800			1200
	SVE9HL9H(T)	900			1300
	SVE0HL9H(T)	1000			1400

# 通風型水平 T 型線槽 (HORIZONTAL TEE)

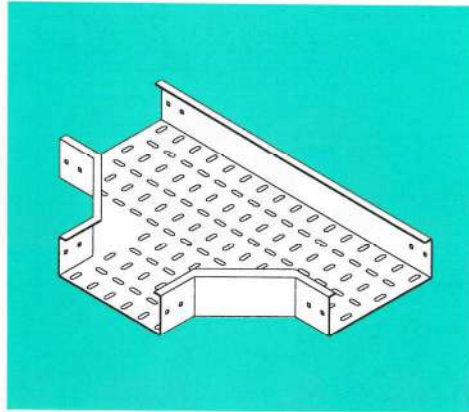

材 質：1.鋁合金 AA5052H32 或 AA1050H14 2.熱軋鐵板(JIS G3131)  
3.鍍鋅鐵板(JIS 3302) 4.不銹鋼(SUS304) (SUS316)  
表面處理：1.(鋁)陽極處理(10 $\mu$ ) 2.電著塗裝(17 $\mu$ )  
3.(鐵)熱浸鍍鋅 (350g/m<sup>2</sup>) 4.靜電粉體塗裝(50 $\mu$ )  
※其他特殊規格亦可接受訂購

MATERIAL：1.ALUMINUM ALLOY AA5052H32 OR AA1050H14  
2.HOT ROLL STEEL SHEET (JIS G3131)  
3.GALVANIZED STEEL SHEET (JIS 3302)  
4.STAINLESS STEEL (SUS304) OR (SUS316)

FINISH：1.ANODIC OXIDATION (10 $\mu$ )  
2.ELECTRODEPOSITING COATING AFTER ANODIC OXIDATION (17 $\mu$ )  
3.HOT DIP GALVANIZED AFTER FABRICATION (350g/m<sup>2</sup>)  
4.POWDER COATING (50 $\mu$ )

※OTHER SIZES(WIDTHS) CAN BE ORDERED

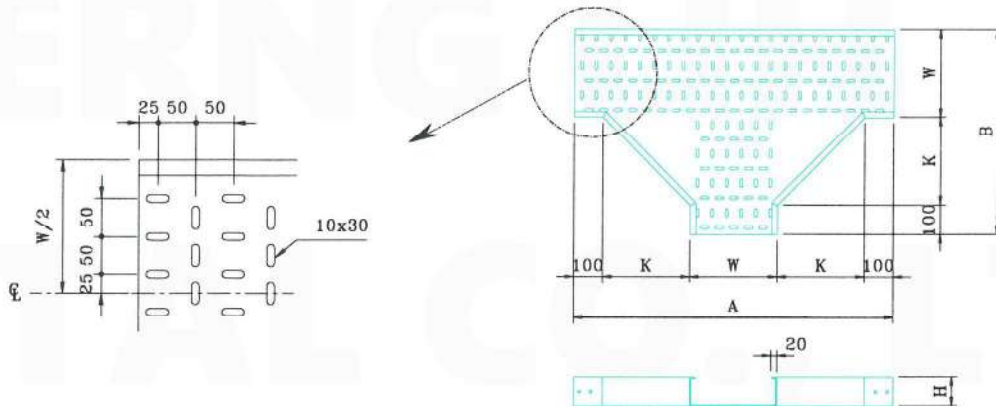

邊槽高度 60H 系列 (60mm HEIGHT SERIES) 厚度 (T)=1.6mm 或 2mm

(Units:mm)

型 號 CAT.NO	線槽寬度 W	邊槽高度 H	斜邊長度 K	總 長 A	總 長 B
SVA1HTH(T)	100	60	150	600	350
SVA2HTH(T)	200			700	450
SVA3HTH(T)	300			800	550
SVA4HTH(T)	400		200	1000	700
SVA5HTH(T)	500			1100	800
SVA6HTH(T)	600			1200	900
SVA7HTH(T)	700		300	1300	1000
SVA8HTH(T)	800			1600	1200
SVA9HTH(T)	900			1700	1300
SVA0HTH(T)	1000	1800		1400	

邊槽高度 80H 系列 (80mm HEIGHT SERIES) 厚度 (T)=1.6mm or 2mm

(Units:mm)

型號 CAT NO	線槽寬度 W	邊槽高度 H	斜邊長度 K	總長 A	總長 B
SVB1HTH(T)	100	80	150	600	350
SVB2HTH(T)	200			700	450
SVB3HTH(T)	300			800	550
SVB4HTH(T)	400		200	1000	700
SVB5HTH(T)	500			1100	800
SVB6HTH(T)	600			1200	900
SVB7HTH(T)	700			1300	1000
SVB8HTH(T)	800		300	1600	1200
SVB9HTH(T)	900			1700	1300
SVB0HTH(T)	1000			1800	1400

邊槽高度 100H 系列 (100mm HEIGHT SERIES) 厚度 (T)=1.6mm or 2mm

(Units:mm)

型號 CAT.NO	線槽寬度 W	邊槽高度 H	斜邊長度 K	總長 A	總長 B
SVC1HTH(T)	100	100	150	600	350
SVC2HTH(T)	200			700	450
SVC3HTH(T)	300			800	550
SVC4HTH(T)	400		200	1000	700
SVC5HTH(T)	500			1100	800
SVC6HTH(T)	600			1200	900
SVC7HTH(T)	700			1300	1000
SVC8HTH(T)	800		300	1600	1200
SVC9HTH(T)	900			1700	1300
SVC0HTH(T)	1000			1800	1400

邊槽高度 120H 系列 (120mm HEIGHT SERIES) 厚度 (T)=1.6mm or 2mm

(Units:mm)

型號 CAT.NO	線槽寬度 W	邊槽高度 H	斜邊長度 K	總長 A	總長 B
SVD1HTH(T)	100	120	150	600	350
SVD2HTH(T)	200			700	450
SVD3HTH(T)	300			800	550
SVD4HTH(T)	400		200	1000	700
SVD5HTH(T)	500			1100	800
SVD6HTH(T)	600			1200	900
SVD7HTH(T)	700			1300	1000
SVD8HTH(T)	800		300	1600	1200
SVD9HTH(T)	900			1700	1300
SVD0HTH(T)	1000			1800	1400

邊槽高度 150H 系列 (150mm HEIGHT SERIES) 厚度 (T)=2mm or 2.6mm

(Units:mm)

型號 CAT.NO	線槽寬度 W	邊槽高度 H	斜邊長度 K	總長 A	總長 B
SVE1HTH(T)	100	150	150	600	350
SVE2HTH(T)	200			700	450
SVE3HTH(T)	300			800	550
SVE4HTH(T)	400		200	1000	700
SVE5HTH(T)	500			1100	800
SVE6HTH(T)	600			1200	900
SVE7HTH(T)	700			1300	1000
SVE8HTH(T)	800		300	1600	1200
SVE9HTH(T)	900			1700	1300
SVE0HTH(T)	1000			1800	1400

# 通風型水平 X 型線槽 (HORIZONTAL CROSS)

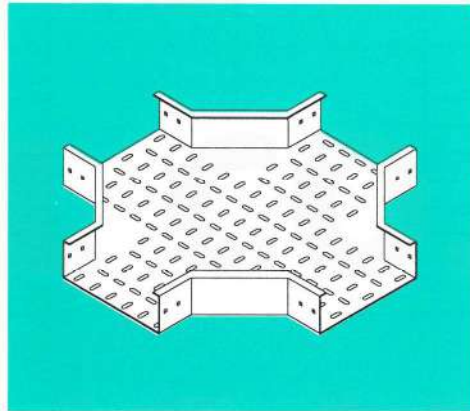

材 質：1.鋁合金 AA5052H32 或 AA1050H14 2.熱軋鐵板(JIS G3131)  
3.鍍鋅鐵板(JIS 3302) 4.不銹鋼(SUS304) (SUS316)

表面處理：1.(鋁)陽極處理(10 $\mu$ ) 2.電著塗裝(17 $\mu$ )  
3.(鐵)熱浸鍍鋅 (350g/m<sup>2</sup>) 4.靜電粉體塗裝(50 $\mu$ )

※其他特殊規格亦可接受訂購

MATERIAL：1.ALUMINUM ALLOY AA5052H32 OR AA1050H14

2.HOT ROLL STEEL SHEET (JIS G3131)

3.GALVANIZED STEEL SHEET (JIS 3302)

4.STAINLESS STEEL (SUS304) OR (SUS316)

F I N I S H：1.ANODIC OXIDATION (10 $\mu$ )

2.ELECTRODEPOSITING COATING AFTER ANODIC OXIDATION (17 $\mu$ )

3.HOT DIP GALVANIZED AFTER FABRICATION (350g/m<sup>2</sup>)

4.POWDER COATING (50 $\mu$ )

※OTHER SIZES(WIDTHS) CAN BE ORDERED

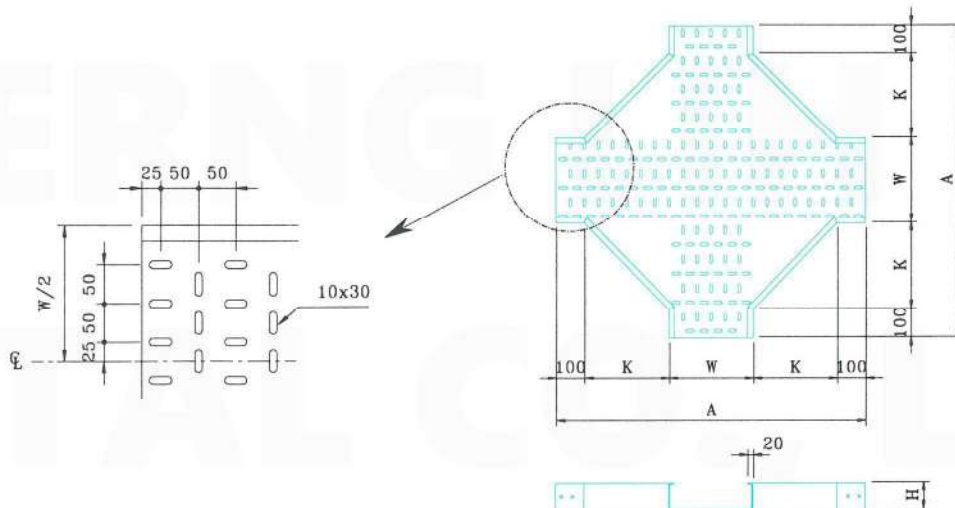

邊槽高度 60H 系列 (60mm HEIGHT SERIES) 厚度 (T)=1.6mm or 2mm

(Units:mm)

邊槽各部尺寸圖	型 號 CAT.NO	線槽寬度 W	邊槽高度 H	斜邊長度 K	總 長 A
	SVA1HXH(T)	100	60	150	600
	SVA2HXH(T)	200			700
	SVA3HXH(T)	300			800
	SVA4HXH(T)	400		200	1000
	SVA5HXH(T)	500			1100
	SVA6HXH(T)	600			1200
	SVA7HXH(T)	700			1300
	SVA8HXH(T)	800		300	1600
	SVA9HXH(T)	900			1700
	SVA0HXH(T)	1000			1800

邊槽高度 80H 系列 (80mm HEIGHT SERIES) 厚度 (T)=1.6mm or 2mm

(Units:mm)

邊槽各部尺寸圖	型號 CAT NO	線槽寬度 W	邊槽高度 H	斜邊長度 K	總長 A
	SVB1HXXH(T)	100	80	150	600
	SVB2HXXH(T)	200			700
	SVB3HXXH(T)	300			800
	SVB4HXXH(T)	400		200	1000
	SVB5HXXH(T)	500			1100
	SVB6HXXH(T)	600			1200
	SVB7HXXH(T)	700			1300
	SVB8HXXH(T)	800		300	1600
	SVB9HXXH(T)	900			1700
	SVB0HXXH(T)	1000			1800

邊槽高度 100H 系列 (100mm HEIGHT SERIES) 厚度 (T)=1.6mm or 2mm

(Units:mm)

邊槽各部尺寸圖	型號 CAT.NO	線槽寬度 W	邊槽高度 H	斜邊長度 K	總長 A
	SVC1HXXH(T)	100	100	150	600
	SVC2HXXH(T)	200			700
	SVC3HXXH(T)	300			800
	SVC4HXXH(T)	400		200	1000
	SVC5HXXH(T)	500			1100
	SVC6HXXH(T)	600			1200
	SVC7HXXH(T)	700			1300
	SVC8HXXH(T)	800		300	1600
	SVC9HXXH(T)	900			1700
	SVC0HXXH(T)	1000			1800

邊槽高度 120H 系列 (120mm HEIGHT SERIES) 厚度 (T)=1.6mm or 2mm

(Units:mm)

邊槽各部尺寸圖	型號 CAT.NO	線槽寬度 W	邊槽高度 H	斜邊長度 K	總長 A
	SVD1HXXH(T)	100	120	150	600
	SVD2HXXH(T)	200			700
	SVD3HXXH(T)	300			800
	SVD4HXXH(T)	400		200	1000
	SVD5HXXH(T)	500			1100
	SVD6HXXH(T)	600			1200
	SVD7HXXH(T)	700			1300
	SVD8HXXH(T)	800		300	1600
	SVD9HXXH(T)	900			1700
	SVD0HXXH(T)	1000			1800

邊槽高度 150H 系列 (150mm HEIGHT SERIES) 厚度 (T)=2mm or 2.6mm

(Units:mm)

邊槽各部尺寸圖	型號 CAT.NO	線槽寬度 W	邊槽高度 H	斜邊長度 K	總長 A
	SVE1HXXH(T)	100	150	150	600
	SVE2HXXH(T)	200			700
	SVE3HXXH(T)	300			800
	SVE4HXXH(T)	400		200	1000
	SVE5HXXH(T)	500			1100
	SVE6HXXH(T)	600			1200
	SVE7HXXH(T)	700			1300
	SVE8HXXH(T)	800		300	1600
	SVE9HXXH(T)	900			1700
	SVE0HXXH(T)	1000			1800

# 通風型 90° 垂直上升線槽 (INSIDE VERTICAL 90°)

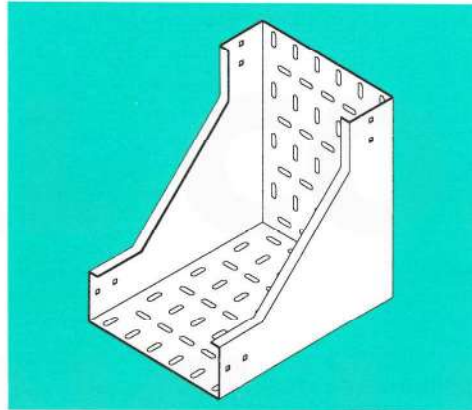

材 質：1.鋁合金 AA5052H32 或 AA1050H14 2.熱軋鐵板(JIS G3131)  
 3.鍍鋅鐵板(JIS 3302) 4.不銹鋼(SUS304) (SUS316)  
 表面處理：1.(鋁)陽極處理(10 $\mu$ ) 2.電著塗裝(17 $\mu$ )  
 3.(鐵)熱浸鍍鋅 (350g/m<sup>2</sup>) 4.靜電粉體塗裝(50 $\mu$ )  
 ※其他特殊規格亦可接受訂購

MATERIAL：1.ALUMINUM ALLOY AA5052H32 OR AA1050H14  
 2.HOT ROLL STEEL SHEET (JIS G3131)  
 3.GALVANIZED STEEL SHEET (JIS 3302)  
 4.STAINLESS STEEL (SUS304) OR (SUS316)

F I N I S H：1.ANODIC OXIDATION (10 $\mu$ )  
 2.ELECTRODEPOSITING COATING AFTER ANODIC OXIDATION (17 $\mu$ )  
 3.HOT DIP GALVANIZED AFTER FABRICATION (350g/m<sup>2</sup>)  
 4.POWDER COATING (50 $\mu$ )

※OTHER SIZES(WIDTHS) CAN BE ORDERED

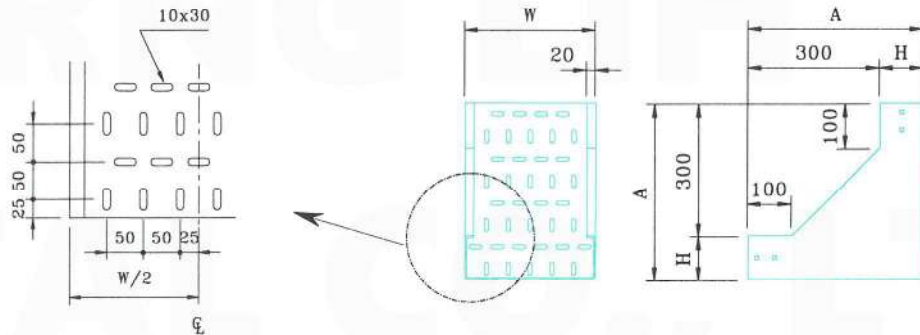

邊槽高度 60H 系列 (60mm HEIGHT SERIES) 厚度 (T)=1.6mm or 2mm

(Units:mm)

邊槽各部尺寸圖	型號 CAT.NO	線槽寬度 W	邊槽高度 H	總長 A
	SVA11VH(T)	100	60	360
	SVA21VH(T)	200		
	SVA31VH(T)	300		
	SVA41VH(T)	400		
	SVA51VH(T)	500		
	SVA61VH(T)	600		
	SVA71VH(T)	700		
	SVA81VH(T)	800		
	SVA91VH(T)	900		
	SVA01VH(T)	1000		

邊槽高度 80H 系列 (80mm HEIGHT SERIES) 厚度 (T)=1.6mm or 2mm

(Units:mm)

邊槽各部尺寸圖	型號 CAT.NO	線槽寬度 W	邊槽高度 H	總長 A
	SVB1IVH(T)	100	80	380
	SVB2IVH(T)	200		
	SVB3IVH(T)	300		
	SVB4IVH(T)	400		
	SVB5IVH(T)	500		
	SVB6IVH(T)	600		
	SVB7IVH(T)	700		
	SVB8IVH(T)	800		
	SVB9IVH(T)	900		
	SVB0IVH(T)	1000		

邊槽高度 100H 系列 (100mm HEIGHT SERIES) 厚度 (T)=1.6mm or 2mm

(Units:mm)

邊槽各部尺寸圖	型號 CAT.NO	線槽寬度 W	邊槽高度 H	總長 A
	SVC1IVH(T)	100	100	400
	SVC2IVH(T)	200		
	SVC3IVH(T)	300		
	SVC4IVH(T)	400		
	SVC5IVH(T)	500		
	SVC6IVH(T)	600		
	SVC7IVH(T)	700		
	SVC8IVH(T)	800		
	SVC9IVH(T)	900		
	SVC0IVH(T)	1000		

邊槽高度 120H 系列 (120mm HEIGHT SERIES) 厚度 (T)=1.6mm or 2mm

(Units:mm)

邊槽各部尺寸圖	型號 CAT.NO	線槽寬度 W	邊槽高度 H	總長 A
	SVD1IVH(T)	100	120	420
	SVD2IVH(T)	200		
	SVD3IVH(T)	300		
	SVD4IVH(T)	400		
	SVD5IVH(T)	500		
	SVD6IVH(T)	600		
	SVD7IVH(T)	700		
	SVD8IVH(T)	800		
	SVD9IVH(T)	900		
	SVD0IVH(T)	1000		

邊槽高度 150H 系列 (150mm HEIGHT SERIES) 厚度 (T)=2mm or 2.6mm

(Units:mm)

邊槽各部尺寸圖	型號 CAT.NO	線槽寬度 W	邊槽高度 H	總長 A
	SVE1IVH(T)	100	150	450
	SVE2IVH(T)	200		
	SVE3IVH(T)	300		
	SVE4IVH(T)	400		
	SVE5IVH(T)	500		
	SVE6IVH(T)	600		
	SVE7IVH(T)	700		
	SVE8IVH(T)	800		
	SVE9IVH(T)	900		
	SVE0IVH(T)	1000		

# 通風型 90° 垂直下降線槽 (OUTSIDE VERTICAL 90°)

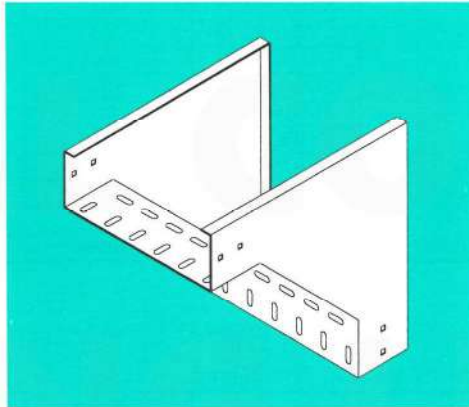

材 質：1.鋁合金 AA5052H32 或 AA1050H14 2.熱軋鐵板(JIS G3131)  
3.鍍鋅鐵板(JIS 3302) 4.不銹鋼(SUS304) (SUS316)  
表面處理：1.(鋁)陽極處理(10 $\mu$ ) 2.電著塗裝(17 $\mu$ )  
3.(鐵)熱浸鍍鋅 (350g/m<sup>2</sup>) 4.靜電粉體塗裝(50 $\mu$ )  
※其他特殊規格亦可接受訂購

MATERIAL: 1. ALUMINUM ALLOY AA5052H32 OR AA1050H14  
2. HOT ROLL STEEL SHEET (JIS G3131)  
3. GALVANIZED STEEL SHEET (JIS 3302)  
4. STAINLESS STEEL (SUS304) OR (SUS316)

F I N I S H : 1. ANODIC OXIDATION ( 10  $\mu$  )  
2. ELECTRODEPOSITING COATING AFTER ANODIC OXIDATION ( 17  $\mu$  )  
3. HOT DIP GALVANIZED AFTER FABRICATION ( 350g/m<sup>2</sup> )  
4. POWDER COATING ( 50  $\mu$  )

※OTHER SIZES(WIDTHS) CAN BE ORDERED

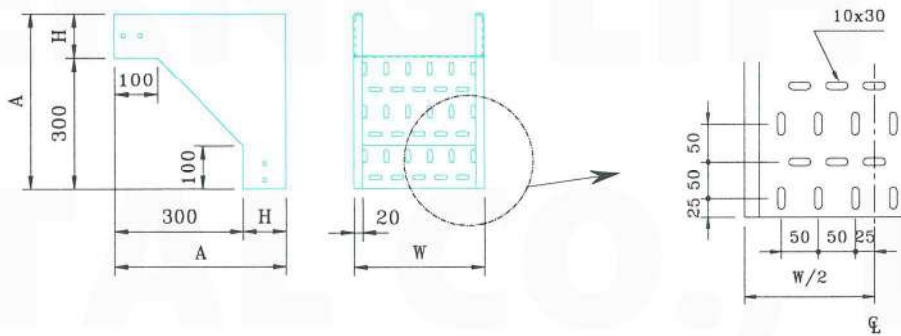

邊槽高度 60H 系列 (60mm HEIGHT SERIES) 厚度 (T)=1.6mm or 2mm

(Units:mm)

邊槽各部尺寸圖	型 號 CAT.NO	線槽寬度 W	邊槽高度 H	總 長 A
	SVA10VH(T)	100	60	360
	SVA20VH(T)	200		
	SVA30VH(T)	300		
	SVA40VH(T)	400		
	SVA50VH(T)	500		
	SVA60VH(T)	600		
	SVA70VH(T)	700		
	SVA80VH(T)	800		
	SVA90VH(T)	900		
	SVA00VH(T)	1000		

邊槽高度 80H 系列 (80mm HEIGHT SERIES) 厚度 (T)=1.6mm or 2mm

(Units:mm)

邊槽各部尺寸圖	型號 CAT NO	線槽寬度 W	邊槽高度 H	總長 A
	SVB1OVH(T)	100	80	380
	SVB2OVH(T)	200		
	SVB3OVH(T)	300		
	SVB4OVH(T)	400		
	SVB5OVH(T)	500		
	SVB6OVH(T)	600		
	SVB7OVH(T)	700		
	SVB8OVH(T)	800		
	SVB9OVH(T)	900		
	SVB0OVH(T)	1000		

邊槽高度 100H 系列 (100mm HEIGHT SERIES) 厚度 (T)=1.6mm or 2mm

(Units:mm)

邊槽各部尺寸圖	型號 CAT.NO	線槽寬度 W	邊槽高度 H	總長 A
	SVC1OVH(T)	100	100	400
	SVC2OVH(T)	200		
	SVC3OVH(T)	300		
	SVC4OVH(T)	400		
	SVC5OVH(T)	500		
	SVC6OVH(T)	600		
	SVC7OVH(T)	700		
	SVC8OVH(T)	800		
	SVC9OVH(T)	900		
	SVC0OVH(T)	1000		

邊槽高度 120H 系列 (120mm HEIGHT SERIES) 厚度 (T)=1.6mm or 2mm

(Units:mm)

邊槽各部尺寸圖	型號 CAT.NO	線槽寬度 W	邊槽高度 H	總長 A
	SVD1OVH(T)	100	120	420
	SVD2OVH(T)	200		
	SVD3OVH(T)	300		
	SVD4OVH(T)	400		
	SVD5OVH(T)	500		
	SVD6OVH(T)	600		
	SVD7OVH(T)	700		
	SVD8OVH(T)	800		
	SVD9OVH(T)	900		
	SVD0OVH(T)	1000		

邊槽高度 150H 系列 (150mm HEIGHT SERIES) 厚度 (T)=2mm or 2.6mm

(Units:mm)

邊槽各部尺寸圖	型號 CAT.NO	線槽寬度 W	邊槽高度 H	總長 A
	SVE1OVH(T)	100	150	450
	SVE2OVH(T)	200		
	SVE3OVH(T)	300		
	SVE4OVH(T)	400		
	SVE5OVH(T)	500		
	SVE6OVH(T)	600		
	SVE7OVH(T)	700		
	SVE8OVH(T)	800		
	SVE9OVH(T)	900		
	SVE0OVH(T)	1000		

# 通風型垂直 T 型線槽 (VERTICAL TEE)

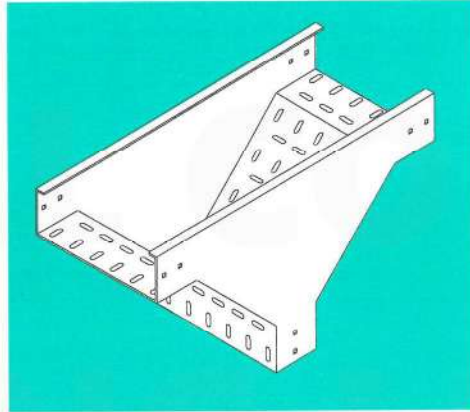

材 質：1.鋁合金 AA5052H32 或 AA1050H14 2.熱軋鐵板(JIS G3131)  
 3.鍍鋅鐵板(JIS 3302) 4.不銹鋼(SUS304) (SUS316)  
 表面處理：1.(鋁)陽極處理(10 $\mu$ ) 2.電著塗裝(17 $\mu$ )  
 3.(鐵)熱浸鍍鋅 (350g/m<sup>2</sup>) 4.靜電粉體塗裝(50 $\mu$ )  
 ※其他特殊規格亦可接受訂購

MATERIAL：1.ALUMINUM ALLOY AA5052H32 OR AA1050H14  
 2.HOT ROLL STEEL SHEET (JIS G3131)  
 3.GALVANIZED STEEL SHEET (JIS 3302)  
 4.STAINLESS STEEL (SUS304) OR (SUS316)

F I N I S H：1.ANODIC OXIDATION (10 $\mu$ )  
 2.ELECTRODEPOSITING COATING AFTER ANODIC OXIDATION (17 $\mu$ )  
 3.HOT DIP GALVANIZED AFTER FABRICATION (350g/m<sup>2</sup>)  
 4.POWDER COATING (50 $\mu$ )

※OTHER SIZES(WIDTHS) CAN BE ORDERED

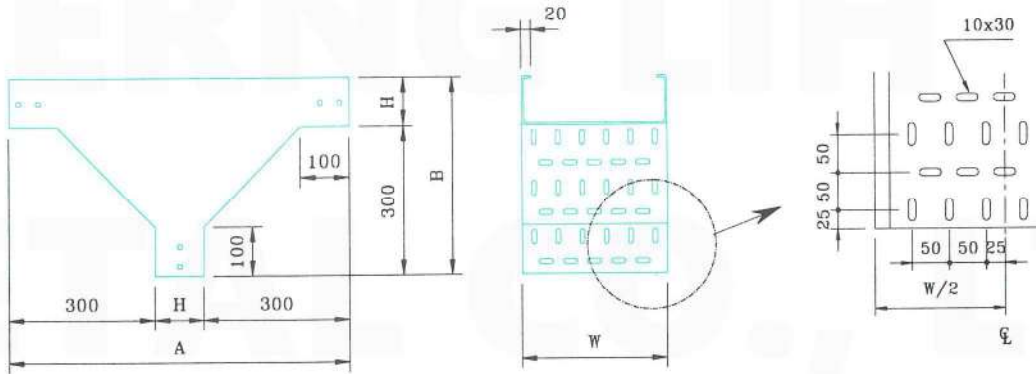

邊槽高度 60H 系列 (60mm HEIGHT SERIES) 厚度 (T)=1.6mm or 2mm

(Units:mm)

邊槽各部尺寸圖	型 號 CAT NO	線槽寬度 W	邊槽高度 H	總 長 A	總 長 B
	SVA1VTH(T)	100	60	660	360
	SVA2VTH(T)	200			
	SVA3VTH(T)	300			
	SVA4VTH(T)	400			
	SVA5VTH(T)	500			
	SVA6VTH(T)	600			
	SVA7VTH(T)	700			
	SVA8VTH(T)	800			
	SVA9VTH(T)	900			
	SVA0VTH(T)	1000			

邊槽高度 80H 系列 (80mm HEIGHT SERIES) 厚度 (T)=1.6mm or 2mm

(Units:mm)

邊槽各部尺寸圖	型號 CAT.NO	線槽寬度 W	邊槽高度 H	總長 A	總長 B
	SVB1VTH(T)	100	80	680	380
	SVB2VTH(T)	200			
	SVB3VTH(T)	300			
	SVB4VTH(T)	400			
	SVB5VTH(T)	500			
	SVB6VTH(T)	600			
	SVB7VTH(T)	700			
	SVB8VTH(T)	800			
	SVB9VTH(T)	900			
	SVB0VTH(T)	1000			

邊槽高度 100H 系列 (100mm HEIGHT SERIES) 厚度 (T)=1.6mm or 2mm

(Units:mm)

邊槽各部尺寸圖	型號 CAT.NO	線槽寬度 W	邊槽高度 H	總長 A	總長 B
	SVC1VTH(T)	100	100	700	400
	SVC2VTH(T)	200			
	SVC3VTH(T)	300			
	SVC4VTH(T)	400			
	SVC5VTH(T)	500			
	SVC6VTH(T)	600			
	SVC7VTH(T)	700			
	SVC8VTH(T)	800			
	SVC9VTH(T)	900			
	SVC0VTH(T)	1000			

邊槽高度 120H 系列 (120mm HEIGHT SERIES) 厚度 (T)=1.6mm or 2mm

(Units:mm)

邊槽各部尺寸圖	型號 CAT.NO	線槽寬度 W	邊槽高度 H	總長 A	總長 B
	SVD1VTH(T)	100	120	720	420
	SVD2VTH(T)	200			
	SVD3VTH(T)	300			
	SVD4VTH(T)	400			
	SVD5VTH(T)	500			
	SVD6VTH(T)	600			
	SVD7VTH(T)	700			
	SVD8VTH(T)	800			
	SVD9VTH(T)	900			
	SVD0VTH(T)	1000			

邊槽高度 150H 系列 (150mm HEIGHT SERIES) 厚度 (T)=2mm or 2.6mm

(Units:mm)

邊槽各部尺寸圖	型號 CAT.NO	線槽寬度 W	邊槽高度 H	總長 A	總長 B
	SVE1VTH(T)	100	150	750	450
	SVE2VTH(T)	200			
	SVE3VTH(T)	300			
	SVE4VTH(T)	400			
	SVE5VTH(T)	500			
	SVE6VTH(T)	600			
	SVE7VTH(T)	700			
	SVE8VTH(T)	800			
	SVE9VTH(T)	900			
	SVE0VTH(T)	1000			

# 通風中心型大小線槽 (BOTH SIDES REDUCER)

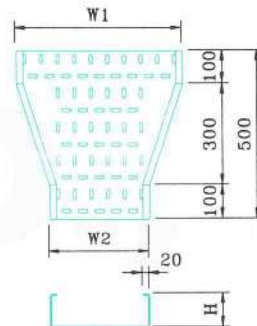
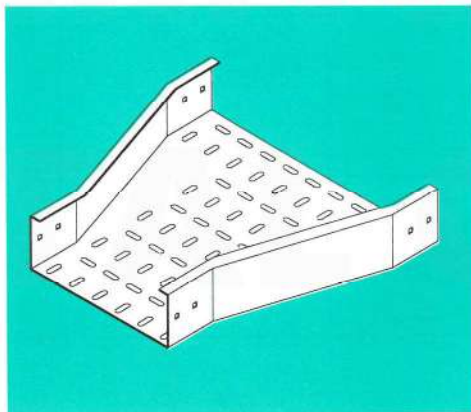

- 材 質 : 1.鋁合金 AA5052H32 或 AA1050H14 2.熱軋鐵板(JIS G3131)  
 3.鍍鋅鐵板(JIS 3302) 4.不銹鋼(SUS304) (SUS316)  
 表面處理 : 1.(鋁)陽極處理(10 $\mu$ ) 2.電著塗裝(17 $\mu$ )  
 3.(鐵)熱浸鍍鋅 (350g/m<sup>2</sup>) 4.靜電粉體塗裝(50 $\mu$ )  
 ※其他特殊規格亦可接受訂購

- MATERIAL : 1.ALUMINUM ALLOY AA5052H32 OR AA1050H14  
 2.HOT ROLL STEEL SHEET (JIS G3131)  
 3.GALVANIZED STEEL SHEET (JIS 3302)  
 4.STAINLESS STEEL (SUS304) OR (SUS316)

- F I N I S H : 1.ANODIC OXIDATION ( 10 $\mu$  )  
 2.ELECTRODEPOSITING COATING AFTER ANODIC OXIDATION ( 17 $\mu$  )  
 3.HOT DIP GALVANIZED AFTER FABRICATION ( 350g/m<sup>2</sup> )  
 4.POWDER COATING ( 50 $\mu$  )

※OTHER SIZES(WIDTHS) CAN BE ORDERED

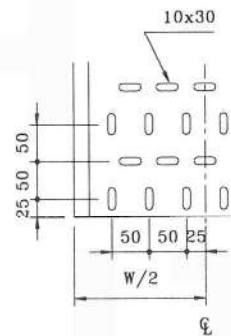

厚度(T)=1.6mm or 2mm

Units:mm

CAT.NO. W1-W2	H	60H	80H	100H	120H	150H
200-100		SVA21RCH(T)	SVB21RCH(T)	SVC21RCH(T)	SVD21RCH(T)	SVE21RCH(T)
300-200		SVA32RCH(T)	SVB32RCH(T)	SVC32RCH(T)	SVD32RCH(T)	SVE32RCH(T)
400-200		SVA42RCH(T)	SVB42RCH(T)	SVC42RCH(T)	SVD42RCH(T)	SVE42RCH(T)
400-300		SVA43RCH(T)	SVB43RCH(T)	SVC43RCH(T)	SVD43RCH(T)	SVE43RCH(T)
500-200		SVA52RCH(T)	SVB52RCH(T)	SVC52RCH(T)	SVD52RCH(T)	SVE52RCH(T)
500-300		SVA53RCH(T)	SVB53RCH(T)	SVC53RCH(T)	SVD53RCH(T)	SVE53RCH(T)
500-400		SVA54RCH(T)	SVB54RCH(T)	SVC54RCH(T)	SVD54RCH(T)	SVE54RCH(T)
600-200		SVA62RCH(T)	SVB62RCH(T)	SVC62RCH(T)	SVD62RCH(T)	SVE62RCH(T)
600-300		SVA63RCH(T)	SVB63RCH(T)	SVC63RCH(T)	SVD63RCH(T)	SVE63RCH(T)
600-400		SVA64RCH(T)	SVB64RCH(T)	SVC64RCH(T)	SVD64RCH(T)	SVE64RCH(T)
600-500		SVA65RCH(T)	SVB65RCH(T)	SVC65RCH(T)	SVD65RCH(T)	SVE65RCH(T)
700-300		SVA73RCH(T)	SVB73RCH(T)	SVC73RCH(T)	SVD73RCH(T)	SVE73RCH(T)
700-400		SVA74RCH(T)	SVB74RCH(T)	SVC74RCH(T)	SVD74RCH(T)	SVE74RCH(T)
700-500		SVA75RCH(T)	SVB75RCH(T)	SVC75RCH(T)	SVD75RCH(T)	SVE75RCH(T)
700-600		SVA76RCH(T)	SVB76RCH(T)	SVC76RCH(T)	SVD76RCH(T)	SVE76RCH(T)
800-300		SVA83RCH(T)	SVB83RCH(T)	SVC83RCH(T)	SVD83RCH(T)	SVE83RCH(T)
800-400		SVA84RCH(T)	SVB84RCH(T)	SVC84RCH(T)	SVD84RCH(T)	SVE84RCH(T)
800-500		SVA85RCH(T)	SVB85RCH(T)	SVC85RCH(T)	SVD85RCH(T)	SVE85RCH(T)
800-600		SVA86RCH(T)	SVB86RCH(T)	SVC86RCH(T)	SVD86RCH(T)	SVE86RCH(T)
800-700		SVA87RCH(T)	SVB87RCH(T)	SVC87RCH(T)	SVD87RCH(T)	SVE87RCH(T)
900-300		SVA93RCH(T)	SVB93RCH(T)	SVC93RCH(T)	SVD93RCH(T)	SVE93RCH(T)
900-400		SVA94RCH(T)	SVB94RCH(T)	SVC94RCH(T)	SVD94RCH(T)	SVE94RCH(T)
900-500		SVA95RCH(T)	SVB95RCH(T)	SVC95RCH(T)	SVD95RCH(T)	SVE95RCH(T)
900-600		SVA96RCH(T)	SVB96RCH(T)	SVC96RCH(T)	SVD96RCH(T)	SVE96RCH(T)
900-700		SVA97RCH(T)	SVB97RCH(T)	SVC97RCH(T)	SVD97RCH(T)	SVE97RCH(T)
900-800		SVA98RCH(T)	SVB98RCH(T)	SVC98RCH(T)	SVD98RCH(T)	SVE98RCH(T)
1000-300		SVA03RCH(T)	SVB03RCH(T)	SVC03RCH(T)	SVD03RCH(T)	SVE03RCH(T)
1000-400		SVA04RCH(T)	SVB04RCH(T)	SVC04RCH(T)	SVD04RCH(T)	SVE04RCH(T)
1000-500		SVA05RCH(T)	SVB05RCH(T)	SVC05RCH(T)	SVD05RCH(T)	SVE05RCH(T)
1000-600		SVA06RCH(T)	SVB06RCH(T)	SVC06RCH(T)	SVD06RCH(T)	SVE06RCH(T)
1000-700		SVA07RCH(T)	SVB07RCH(T)	SVC07RCH(T)	SVD07RCH(T)	SVE07RCH(T)
1000-800		SVA08RCH(T)	SVB08RCH(T)	SVC08RCH(T)	SVD08RCH(T)	SVE08RCH(T)
1000-900		SVA09RCH(T)	SVB09RCH(T)	SVC09RCH(T)	SVD09RCH(T)	SVE09RCH(T)

# 通風左縮型大小線槽 (LEFT HAND REDUCER)

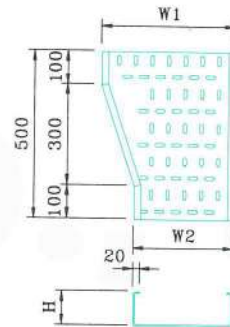
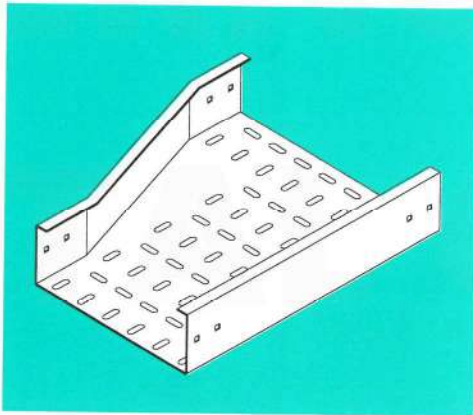

材 質：1.鋁合金 AA5052H32 或 AA1050H14 2.熱軋鐵板(JIS G3131)  
3.鍍鋅鐵板(JIS 3302) 4.不銹鋼(SUS304) (SUS316)  
表面處理：1.(鋁)陽極處理(10 $\mu$ ) 2.電著塗裝(17 $\mu$ )  
3.(鐵)熱浸鍍鋅 (350g/m<sup>2</sup>) 4.靜電粉體塗裝(50 $\mu$ )  
※其他特殊規格亦可接受訂購

MATERIAL：1.ALUMINUM ALLOY AA5052H32 OR AA1050H14  
2.HOT ROLL STEEL SHEET (JIS G3131)  
3.GALVANIZED STEEL SHEET (JIS 3302)  
4.STAINLESS STEEL (SUS304) OR (SUS316)

FINISH：1.ANODIC OXIDATION (10 $\mu$ )  
2.ELECTRODEPOSITING COATING AFTER ANODIC OXIDATION (17 $\mu$ )  
3.HOT DIP GALVANIZED AFTER FABRICATION (350g/m<sup>2</sup>)  
4.POWDER COATING (50 $\mu$ )

※OTHER SIZES(WIDTHS) CANBE TO ORDER

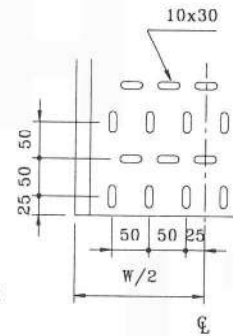

厚度(T)=1.6mm or 2mm

Units:mm

CAT.NO. W1-W2	H	60H	80H	100H	120H	150H
200-100		SVA21RLH(T)	SVB21RLH(T)	SVC21RLH(T)	SVD21RLH(T)	SVE21RLH(T)
300-200		SVA32RLH(T)	SVB32RLH(T)	SVC32RLH(T)	SVD32RLH(T)	SVE32RLH(T)
400-200		SVA42RLH(T)	SVB42RLH(T)	SVC42RLH(T)	SVD42RLH(T)	SVE42RLH(T)
400-300		SVA43RLH(T)	SVB43RLH(T)	SVC43RLH(T)	SVD43RLH(T)	SVE43RLH(T)
500-200		SVA52RLH(T)	SVB52RLH(T)	SVC52RLH(T)	SVD52RLH(T)	SVE52RLH(T)
500-300		SVA53RLH(T)	SVB53RLH(T)	SVC53RLH(T)	SVD53RLH(T)	SVE53RLH(T)
500-400		SVA54RLH(T)	SVB54RLH(T)	SVC54RLH(T)	SVD54RLH(T)	SVE54RLH(T)
600-200		SVA62RLH(T)	SVB62RLH(T)	SVC62RLH(T)	SVD62RLH(T)	SVE62RLH(T)
600-300		SVA63RLH(T)	SVB63RLH(T)	SVC63RLH(T)	SVD63RLH(T)	SVE63RLH(T)
600-400		SVA64RLH(T)	SVB64RLH(T)	SVC64RLH(T)	SVD64RLH(T)	SVE64RLH(T)
600-500		SVA65RLH(T)	SVB65RLH(T)	SVC65RLH(T)	SVD65RLH(T)	SVE65RLH(T)
700-300		SVA73RLH(T)	SVB73RLH(T)	SVC73RLH(T)	SVD73RLH(T)	SVE73RLH(T)
700-400		SVA74RLH(T)	SVB74RLH(T)	SVC74RLH(T)	SVD74RLH(T)	SVE74RLH(T)
700-500		SVA75RLH(T)	SVB75RLH(T)	SVC75RLH(T)	SVD75RLH(T)	SVE75RLH(T)
700-600		SVA76RLH(T)	SVB76RLH(T)	SVC76RLH(T)	SVD76RLH(T)	SVE76RLH(T)
800-300		SVA83RLH(T)	SVB83RLH(T)	SVC83RLH(T)	SVD83RLH(T)	SVE83RLH(T)
800-400		SVA84RLH(T)	SVB84RLH(T)	SVC84RLH(T)	SVD84RLH(T)	SVE84RLH(T)
800-500		SVA85RLH(T)	SVB85RLH(T)	SVC85RLH(T)	SVD85RLH(T)	SVE85RLH(T)
800-600		SVA86RLH(T)	SVB86RLH(T)	SVC86RLH(T)	SVD86RLH(T)	SVE86RLH(T)
800-700		SVA87RLH(T)	SVB87RLH(T)	SVC87RLH(T)	SVD87RLH(T)	SVE87RLH(T)
900-300		SVA93RLH(T)	SVB93RLH(T)	SVC93RLH(T)	SVD93RLH(T)	SVE93RLH(T)
900-400		SVA94RLH(T)	SVB94RLH(T)	SVC94RLH(T)	SVD94RLH(T)	SVE94RLH(T)
900-500		SVA95RLH(T)	SVB95RLH(T)	SVC95RLH(T)	SVD95RLH(T)	SVE95RLH(T)
900-600		SVA96RLH(T)	SVB96RLH(T)	SVC96RLH(T)	SVD96RLH(T)	SVE96RLH(T)
900-700		SVA97RLH(T)	SVB97RLH(T)	SVC97RLH(T)	SVD97RLH(T)	SVE97RLH(T)
900-800		SVA98RLH(T)	SVB98RLH(T)	SVC98RLH(T)	SVD98RLH(T)	SVE98RLH(T)
1000-300		SVA03RLH(T)	SVB03RLH(T)	SVC03RLH(T)	SVD03RLH(T)	SVE03RLH(T)
1000-400		SVA04RLH(T)	SVB04RLH(T)	SVC04RLH(T)	SVD04RLH(T)	SVE04RLH(T)
1000-500		SVA05RLH(T)	SVB05RLH(T)	SVC05RLH(T)	SVD05RLH(T)	SVE05RLH(T)
1000-600		SVA06RLH(T)	SVB06RLH(T)	SVC06RLH(T)	SVD06RLH(T)	SVE06RLH(T)
1000-700		SVA07RLH(T)	SVB07RLH(T)	SVC07RLH(T)	SVD07RLH(T)	SVE07RLH(T)
1000-800		SVA08RLH(T)	SVB08RLH(T)	SVC08RLH(T)	SVD08RLH(T)	SVE08RLH(T)
1000-900		SVA09RLH(T)	SVB09RLH(T)	SVC09RLH(T)	SVD09RLH(T)	SVE09RLH(T)

# 通風右縮型大小線槽 (RIGHT HAND REDUCER)

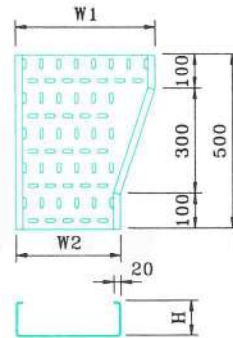
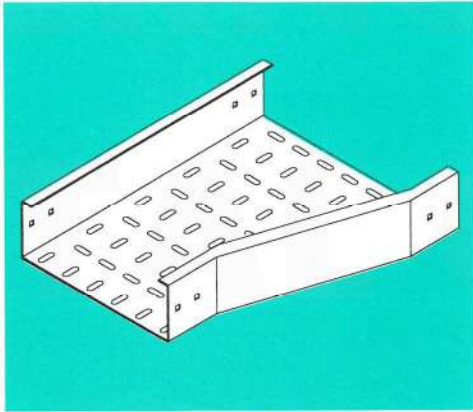

材 質 : 1.鋁合金 AA5052H32 或 AA1050H14 2.熱軋鐵板(JIS G3131)  
3.鍍鋅鐵板(JIS 3302) 4.不銹鋼(SUS304) (SUS316)  
表面處理 : 1.(鋁)陽極處理(10 $\mu$ ) 2.電著塗裝(17 $\mu$ )  
3.(鐵)熱浸鍍鋅 (350g/m<sup>2</sup>) 4.靜電粉體塗裝(50 $\mu$ )  
※其他特殊規格亦可接受訂購

MATERIAL : 1.ALUMINUM ALLOY AA5052H32 OR AA1050H14  
2.HOT ROLL STEEL SHEET (JIS G3131)  
3.GALVANIZED STEEL SHEET (JIS 3302)  
4.STAINLESS STEEL (SUS304) OR (SUS316)

FINISH : 1.ANODIC OXIDATION (10 $\mu$ )  
2.ELECTRODEPOSITING COATING AFTER ANODIC OXIDATION (17 $\mu$ )  
3.HOT DIP GALVANIZED AFTER FABRICATION (350g/m<sup>2</sup>)  
4.POWDER COATING (50 $\mu$ )

※OTHER SIZES(WIDTHS) CAN BE ORDERED

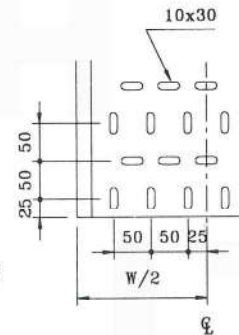

厚度(T)=1.6mm or 2mm

Units:mm

CAT.NO. W1-W2	H	60H	80H	100H	120H	150H
200-100		SVA21RRH(T)	SVB21RRH(T)	SVC21RRH(T)	SVD21RRH(T)	SVE21RRH(T)
300-200		SVA32RRH(T)	SVB32RRH(T)	SVC32RRH(T)	SVD32RRH(T)	SVE32RRH(T)
400-200		SVA42RRH(T)	SVB42RRH(T)	SVC42RRH(T)	SVD42RRH(T)	SVE42RRH(T)
400-300		SVA43RRH(T)	SVB43RRH(T)	SVC43RRH(T)	SVD43RRH(T)	SVE43RRH(T)
500-200		SVA52RRH(T)	SVB52RRH(T)	SVC52RRH(T)	SVD52RRH(T)	SVE52RRH(T)
500-300		SVA53RRH(T)	SVB53RRH(T)	SVC53RRH(T)	SVD53RRH(T)	SVE53RRH(T)
500-400		SVA54RRH(T)	SVB54RRH(T)	SVC54RRH(T)	SVD54RRH(T)	SVE54RRH(T)
600-200		SVA62RRH(T)	SVB62RRH(T)	SVC62RRH(T)	SVD62RRH(T)	SVE62RRH(T)
600-300		SVA63RRH(T)	SVB63RRH(T)	SVC63RRH(T)	SVD63RRH(T)	SVE63RRH(T)
600-400		SVA64RRH(T)	SVB64RRH(T)	SVC64RRH(T)	SVD64RRH(T)	SVE64RRH(T)
600-500		SVA65RRH(T)	SVB65RRH(T)	SVC65RRH(T)	SVD65RRH(T)	SVE65RRH(T)
700-300		SVA73RRH(T)	SVB73RRH(T)	SVC73RRH(T)	SVD73RRH(T)	SVE73RRH(T)
700-400		SVA74RRH(T)	SVB74RRH(T)	SVC74RRH(T)	SVD74RRH(T)	SVE74RRH(T)
700-500		SVA75RRH(T)	SVB75RRH(T)	SVC75RRH(T)	SVD75RRH(T)	SVE75RRH(T)
700-600		SVA76RRH(T)	SVB76RRH(T)	SVC76RRH(T)	SVD76RRH(T)	SVE76RRH(T)
800-300		SVA83RRH(T)	SVB83RRH(T)	SVC83RRH(T)	SVD83RRH(T)	SVE83RRH(T)
800-400		SVA84RRH(T)	SVB84RRH(T)	SVC84RRH(T)	SVD84RRH(T)	SVE84RRH(T)
800-500		SVA85RRH(T)	SVB85RRH(T)	SVC85RRH(T)	SVD85RRH(T)	SVE85RRH(T)
800-600		SVA86RRH(T)	SVB86RRH(T)	SVC86RRH(T)	SVD86RRH(T)	SVE86RRH(T)
800-700		SVA87RRH(T)	SVB87RRH(T)	SVC87RRH(T)	SVD87RRH(T)	SVE87RRH(T)
900-300		SVA93RRH(T)	SVB93RRH(T)	SVC93RRH(T)	SVD93RRH(T)	SVE93RRH(T)
900-400		SVA94RRH(T)	SVB94RRH(T)	SVC94RRH(T)	SVD94RRH(T)	SVE94RRH(T)
900-500		SVA95RRH(T)	SVB95RRH(T)	SVC95RRH(T)	SVD95RRH(T)	SVE95RRH(T)
900-600		SVA96RRH(T)	SVB96RRH(T)	SVC96RRH(T)	SVD96RRH(T)	SVE96RRH(T)
900-700		SVA97RRH(T)	SVB97RRH(T)	SVC97RRH(T)	SVD97RRH(T)	SVE97RRH(T)
900-800		SVA98RRH(T)	SVB98RRH(T)	SVC98RRH(T)	SVD98RRH(T)	SVE98RRH(T)
1000-300		SVA03RRH(T)	SVB03RRH(T)	SVC03RRH(T)	SVD03RRH(T)	SVE03RRH(T)
1000-400		SVA04RRH(T)	SVB04RRH(T)	SVC04RRH(T)	SVD04RRH(T)	SVE04RRH(T)
1000-500		SVA05RRH(T)	SVB05RRH(T)	SVC05RRH(T)	SVD05RRH(T)	SVE05RRH(T)
1000-600		SVA06RRH(T)	SVB06RRH(T)	SVC06RRH(T)	SVD06RRH(T)	SVE06RRH(T)
1000-700		SVA07RRH(T)	SVB07RRH(T)	SVC07RRH(T)	SVD07RRH(T)	SVE07RRH(T)
1000-800		SVA08RRH(T)	SVB08RRH(T)	SVC08RRH(T)	SVD08RRH(T)	SVE08RRH(T)
1000-900		SVA09RRH(T)	SVB09RRH(T)	SVC09RRH(T)	SVD09RRH(T)	SVE09RRH(T)

# 電纜線槽型號說明表

## (HOW TO ORDER)

例如：S D C 1 S H (T)  
 : : : : : : :  
 材 型 線槽 線槽 線槽 表面 線槽  
 質 式 高度 寬度 角度 處理 厚度  
 ① ② ③ ④ ⑤ ⑥ ⑦

代號說明：

材 質	A：鋁 S：熱軋鐵板 (4)：不銹鋼 304 (6)：不銹鋼 316 G：鍍鋅鐵板
型 式	L：梯型線架 D：密閉型線槽 V：通風型線槽 W：底板加強型線槽
邊槽高度	A：60H B：80H C：100H D：120H E：150H F：200H G：250H H：300H
線槽寬度	1：100W 2：200W 3：300W 4：400W 5：500W 6：600W 7：700W 8：800W 9：900W 0：1000W
線槽角度	S：直式 HL：水平接頭 HT：水平三通接頭 HX：水平四通接頭 IV：垂直上升接頭 OV：垂直下降接頭 VT：垂直三通接頭 RC：中心型大小接頭 RL：左縮型大小接頭 RR：右縮型大小接頭
表面處理	A：陽極處理 E：電著塗裝 H：熱浸鍍鋅 P：靜電粉體塗裝
邊槽厚度	標準厚度(T)：1.6mm 2mm

ILLUSTRATION：

① MATERIAL	A：ALUMINUM S：HOT ROLL STEEL SHEET (4)：STAINLESS STEEL304 (6)：STAINLESS STEEL316 G：GALVANIZED STEEL SHEET
② TYPE	L：LADDER TYPE D：SOLID BOTTOM TYPE V：VENTILATED TYPE W：CORRUGATED TYPE
③ HEIGHT OF SIDE RAIL	A：60H B：80H C：100H D：120H E：150H F：200H G：250H H：300H
④ WIDTH	1：100W 2：200W 3：300W 4：400W 5：500W 6：600W 7：700W 8：800W 9：900W 0：1000W
⑤ STRAIGHT TRAY OR ELBOWS	S：STRAIGHT HL：HORIZONTAL ELBOW HT：HORIZONTAL TEE HX：HORIZONTAL CROSS IV：INSIDE VERTICAL ELBOW OV：OUTSIDE VERTICAL ELBOW VT：VERTICAL TEE RC：BOTH SKDES RR：LEFT HAND RL：RIGHT HAND
⑥ FINISHES	A：ANODIC OXIDATION E：ELECTORDEPOSITED COATING AFTER ANODIC OXIDATION H：HOT DIP GALVANIZING AFTER FORMING P：POWDER COATING
⑦ THICKNESS	(T)：1.6mm 2mm

# 密閉型直式電纜線槽

## (SOLID BOTTOM STRAIGHT TYPE CABLE DUCT)

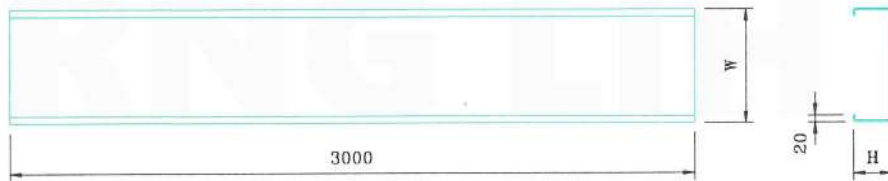
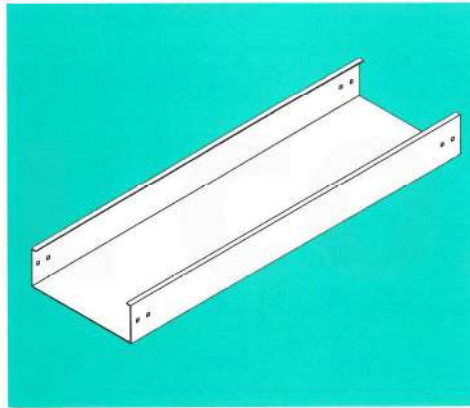

材 質：1.鋁合金 AA5052H32 或 AA1050H14 2.熱軋鐵板(JIS G3131)  
 3.鍍鋅鐵板(JIS 3302) 4.不銹鋼(SUS304) (SUS316)  
 表面處理：1.(鋁)陽極處理(10 $\mu$ ) 2.電著塗裝(17 $\mu$ )  
 3.(鐵)熱浸鍍鋅 (350g/m<sup>2</sup>) 4.靜電粉體塗裝(50 $\mu$ )  
 ※其他特殊規格亦可接受訂購

MATERIAL：1.ALUMINUM ALLOY AA5052H32 OR AA1050H14  
 2.HOT ROLL STEEL SHEET (JIS G3131)  
 3.GALVANIZED STEEL SHEET (JIS 3302)  
 4.STAINLESS STEEL (SUS304) OR (SUS316)

F I N I S H：1.ANODIC OXIDATION ( 10 $\mu$  )  
 2.ELECTRODEPOSITING COATING AFTER ANODIC OXIDATION ( 17 $\mu$  )  
 3.HOT DIP GALVANIZED AFTER FABRICATION ( 350g/m<sup>2</sup> )  
 4.POWDER COATING ( 50 $\mu$  )

※OTHER SIZES(WIDTHS) CAN BE ORDERED

邊槽高度 100H 系列 (100mm HEIGHT SERIES) 厚度(T)=1.6mm or 2mm (Units:mm)

邊槽各部尺寸圖	型 號 CAT.NO	線槽寬度 W	線槽高度 H	總 長 L
	SDC1SH(T)	100	100	3000
	SDC2SH(T)	200		
	SDC3SH(T)	300		
	SDC4SH(T)	400		
	SDC5SH(T)	500		
	SDC6SH(T)	600		
	SDC7SH(T)	700		
	SDC8SH(T)	800		
	SDC9SH(T)	900		
	SDC0SH(T)	1000		

邊槽高度 150H 系列 (150mm HEIGHT SERIES) 厚度(T)=2mm or 2.6mm (Units:mm)

邊槽各部尺寸圖	型 號 CAT.NO	線槽寬度 W	線槽高度 H	總 長 L
	SDE1SH(T)	100	150	3000
	SDE2SH(T)	200		
	SDE3SH(T)	300		
	SDE4SH(T)	400		
	SDE5SH(T)	500		
	SDE6SH(T)	600		
	SDE7SH(T)	700		
	SDE8SH(T)	800		
	SDE9SH(T)	900		
	SDE0SH(T)	1000		

邊槽高度 200H 系列 (200mm HEIGHT SERIES) 厚度(T)=2mm or 2.6mm

(Units:mm)

邊槽各部尺寸圖	型號 CAT.NO	線槽寬度 W	線槽高度 H	總長 L
	SDF1SH(T)	100	200	3000
	SDF2SH(T)	200		
	SDF3SH(T)	300		
	SDF4SH(T)	400		
	SDF5SH(T)	500		
	SDF6SH(T)	600		
	SDF7SH(T)	700		
	SDF8SH(T)	800		
	SDF9SH(T)	900		
	SDF0SH(T)	1000		

邊槽高度 250H 系列 (250mm HEIGHT SERIES) 厚度(T)=2mm or 2.6mm

(Units:mm)

邊槽各部尺寸圖	型號 CAT.NO	線槽寬度 W	線槽高度 H	總長 L
	SDG1SH(T)	100	250	3000
	SDG2SH(T)	200		
	SDG3SH(T)	300		
	SDG4SH(T)	400		
	SDG5SH(T)	500		
	SDG6SH(T)	600		
	SDG7SH(T)	700		
	SDG8SH(T)	800		
	SDG9SH(T)	900		
	SDG0SH(T)	1000		

邊槽高度 300H 系列 (300mm HEIGHT SERIES) 厚度(T)=2mm or 2.6mm

(Units:mm)

邊槽各部尺寸圖	型號 CAT.NO	線槽寬度 W	線槽高度 H	總長 L
	SDH1SH(T)	100	300	3000
	SDH2SH(T)	200		
	SDH3SH(T)	300		
	SDH4SH(T)	400		
	SDH5SH(T)	500		
	SDH6SH(T)	600		
	SDH7SH(T)	700		
	SDH8SH(T)	800		
	SDH9SH(T)	900		
	SDH0SH(T)	1000		

# 密閉型水平 90° 線槽 (HORIZONTAL 90°)

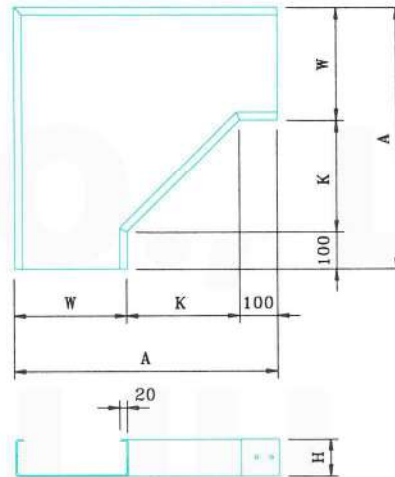
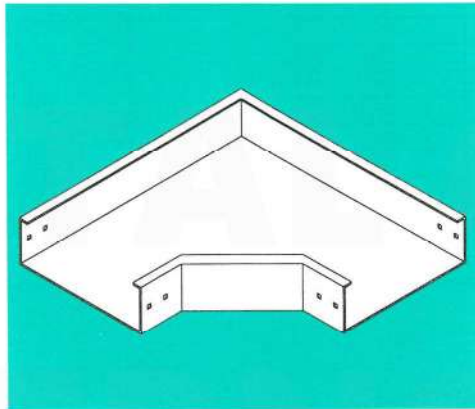

材 質：1.鋁合金 AA5052H32 或 AA1050H14 2.熱軋鐵板(JIS G3131)  
 3.鍍鋅鐵板(JIS 3302) 4.不銹鋼(SUS304) (SUS316)  
 表面處理：1.(鋁)陽極處理(10 $\mu$ ) 2.電著塗裝(17 $\mu$ )  
 3.(鐵)熱浸鍍鋅 (350g/m<sup>2</sup>) 4.靜電粉體塗裝(50 $\mu$ )  
 ※其他特殊規格亦可接受訂購

MATERIAL：1.ALUMINUM ALLOY AA5052H32 OR AA1050H14  
 2.HOT ROLL STEEL SHEET (JIS G3131)  
 3.GALVANIZED STEEL SHEET (JIS 3302)  
 4.STAINLESS STEEL (SUS304) OR (SUS316)

F I N I S H：1.ANODIC OXIDATION (10 $\mu$ )  
 2.ELECTRODEPOSITING COATING AFTER ANODIC OXIDATION (17 $\mu$ )  
 3.HOT DIP GALVANIZED AFTER FABRICATION (350g/m<sup>2</sup>)  
 4.POWDER COATING (50 $\mu$ )

※OTHER SIZES(WIDTHS) CAN BE ORDERED

邊槽高度 100H 系列 (100mm HEIGHT SERIES) 厚度 (T)=1.6mm or 2mm

(Units:mm)

邊槽各部尺寸圖	型 號 CAT NO	線槽寬度 W	邊槽高度 H	斜邊長度 K	總 長 A	
	SDC1HL9H(T)	100	100	150	350	
	SDC2HL9H(T)	200			450	
	SDC3HL9H(T)	300			550	
	SDC4HL9H(T)	400		200	200	700
	SDC5HL9H(T)	500				800
	SDC6HL9H(T)	600				900
	SDC7HL9H(T)	700				1000
	SDC8HL9H(T)	800				1200
	SDC9HL9H(T)	900				1300
	SDC0HL9H(T)	1000		300	1400	

邊槽高度 150H 系列 (150mm HEIGHT SERIES) 厚度 (T)=2mm or 2.6mm

(Units:mm)

邊槽各部尺寸圖	型 號 CAT NO	線槽寬度 W	邊槽高度 H	斜邊長度 K	總 長 A	
	SDE1HL9H(T)	100	150	150	350	
	SDE2HL9H(T)	200			450	
	SDE3HL9H(T)	300			550	
	SDE4HL9H(T)	400		200	200	700
	SDE5HL9H(T)	500				800
	SDE6HL9H(T)	600				900
	SDE7HL9H(T)	700				1000
	SDE8HL9H(T)	800				1200
	SDE9HL9H(T)	900				1300
	SDE0HL9H(T)	1000		300	1400	

邊槽高度 200H 系列 (200mm HEIGHT SERIES) 厚度 (T)=2mm or 2.6mm

(Units:mm)

邊槽各部尺寸圖	型號 CAT NO	線槽寬度 W	邊槽高度 H	斜邊長度 K	總長 A	
	SDF1HL9H(T)	100	200	150	350	
	SDF2HL9H(T)	200			450	
	SDF3HL9H(T)	300			550	
	SDF4HL9H(T)	400		200	200	700
	SDF5HL9H(T)	500				800
	SDF6HL9H(T)	600				900
	SDF7HL9H(T)	700				1000
	SDF8HL9H(T)	800		300	300	1200
	SDF9HL9H(T)	900				1300
	SDF0HL9H(T)	1000				1400

邊槽高度 250H 系列 (250mm HEIGHT SERIES) 厚度 (T)=2mm or 2.6mm

(Units:mm)

邊槽各部尺寸圖	型號 CAT NO	線槽寬度 W	邊槽高度 H	斜邊長度 K	總長 A	
	SDG1HL9H(T)	100	250	150	350	
	SDG2HL9H(T)	200			450	
	SDG3HL9H(T)	300			550	
	SDG4HL9H(T)	400		200	200	700
	SDG5HL9H(T)	500				800
	SDG6HL9H(T)	600				900
	SDG7HL9H(T)	700				1000
	SDG8HL9H(T)	800		300	300	1200
	SDG9HL9H(T)	900				1300
	SDG0HL9H(T)	1000				1400

邊槽高度 300H 系列 (300mm HEIGHT SERIES) 厚度 (T)=2mm or 2.6mm

(Units:mm)

邊槽各部尺寸圖	型號 CAT NO	線槽寬度 W	邊槽高度 H	斜邊長度 K	總長 A	
	SDH1HL9H(T)	100	300	150	350	
	SDH2HL9H(T)	200			450	
	SDH3HL9H(T)	300			550	
	SDH4HL9H(T)	400		200	200	700
	SDH5HL9H(T)	500				800
	SDH6HL9H(T)	600				900
	SDH7HL9H(T)	700				1000
	SDH8HL9H(T)	800		300	300	1200
	SDH9HL9H(T)	900				1300
	SDH0HL9H(T)	1000				1400

# 密閉型水平 T 型線槽 (HORIZONTAL TEE)

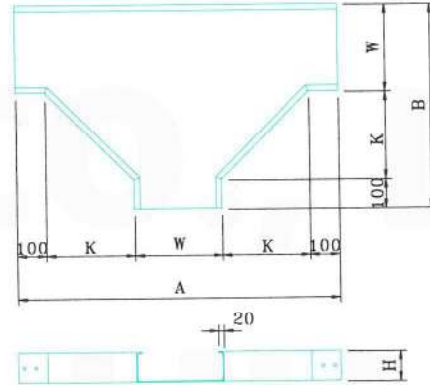
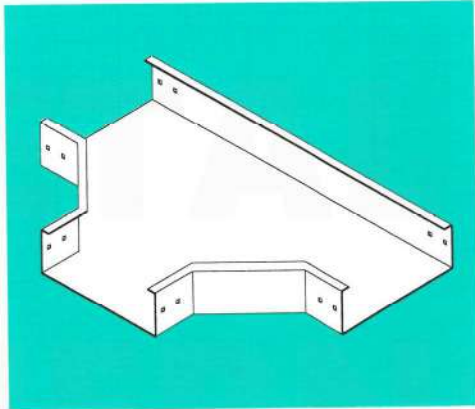

材 質：1.鋁合金 AA5052H32 或 AA1050H14 2.熱軋鐵板(JIS G3131)  
3.鍍鋅鐵板(JIS 3302) 4.不銹鋼(SUS304) (SUS316)  
表面處理：1.(鋁)陽極處理(10 $\mu$ ) 2.電著塗裝(17 $\mu$ )  
3.(鐵)熱浸鍍鋅 (350g/m<sup>2</sup>) 4.靜電粉體塗裝(50 $\mu$ )  
※其他特殊規格亦可接受訂購

MATERIAL：1.ALUMINUM ALLOY AA5052H32 OR AA1050H14  
2.HOT ROLL STEEL SHEET (JIS G3131)  
3.GALVANIZED STEEL SHEET (JIS 3302)  
4.STAINLESS STEEL (SUS304).OR (SUS316)

FINISH：1.ANODIC OXIDATION (10 $\mu$ )  
2.ELECTRODEPOSITING COATING AFTER ANODIC OXIDATION (17 $\mu$ )  
3.HOT DIP GALVANIZED AFTER FABRICATION (350g/m<sup>2</sup>)  
4.POWDER COATING (50 $\mu$ )  
※OTHER SIZES(WIDTHS) CAN BE ORDERED

邊槽高度 100H 系列 (100mm HEIGHT SERIES) 厚度 (T)=1.6mm or 2mm (Units:mm)

型號 CAT.NO	線槽寬度 W	邊槽高度 H	斜邊長度 K	總長 A	總長 B
SDC1HTH(T)	100	100	150	600	350
SDC2HTH(T)	200			700	450
SDC3HTH(T)	300			800	550
SDC4HTH(T)	400			1000	700
SDC5HTH(T)	500		200	1100	800
SDC6HTH(T)	600			1200	900
SDC7HTH(T)	700			1300	1000
SDC8HTH(T)	800			1600	1200
SDC9HTH(T)	900		300	1700	1300
SDC0HTH(T)	1000			1800	1400

邊槽高度 150H 系列 (150mm HEIGHT SERIES) 厚度 (T)=2mm or 2.6mm (Units:mm)

型號 CAT.NO	線槽寬度 W	邊槽高度 H	斜邊長度 K	總長 A	總長 B
SDE1HTH(T)	100	150	150	600	350
SDE2HTH(T)	200			700	450
SDE3HTH(T)	300			800	550
SDE4HTH(T)	400			1000	700
SDE5HTH(T)	500		200	1100	800
SDE6HTH(T)	600			1200	900
SDE7HTH(T)	700			1300	1000
SDE8HTH(T)	800			1600	1200
SDE9HTH(T)	900		300	1700	1300
SDE0HTH(T)	1000			1800	1400

邊槽高度 200H 系列 (200mm HEIGHT SERIES) 厚度 (T)=2mm or 2.6mm (Units:mm)

型號 CAT.NO	線槽寬度 W	邊槽高度 H	斜邊長度 K	總長 A	總長 B
SDF1HHTH(T)	100	200	150	600	350
SDF2HHTH(T)	200			700	450
SDF3HHTH(T)	300			800	550
SDF4HHTH(T)	400		200	1000	700
SDF5HHTH(T)	500			1100	800
SDF6HHTH(T)	600			1200	900
SDF7HHTH(T)	700			1300	1000
SDF8HHTH(T)	800		300	1600	1200
SDF9HHTH(T)	900			1700	1300
SDF0HHTH(T)	1000			1800	1400

邊槽高度 250H 系列 (250mm HEIGHT SERIES) 厚度 (T)=2mm or 2.6mm (Units:mm)

型號 CAT.NO	線槽寬度 W	邊槽高度 H	斜邊長度 K	總長 A	總長 B
SDG1HHTH(T)	100	250	150	600	350
SDG2HHTH(T)	200			700	450
SDG3HHTH(T)	300			800	550
SDG4HHTH(T)	400		200	1000	700
SDG5HHTH(T)	500			1100	800
SDG6HHTH(T)	600			1200	900
SDG7HHTH(T)	700			1300	1000
SDG8HHTH(T)	800		300	1600	1200
SDG9HHTH(T)	900			1700	1300
SDG0HHTH(T)	1000			1800	1400

邊槽高度 300H 系列 (300mm HEIGHT SERIES) 厚度 (T)=2mm or 2.6mm (Units:mm)

型號 CAT.NO	線槽寬度 W	邊槽高度 H	斜邊長度 K	總長 A	總長 B
SDH1HHTH(T)	100	300	150	600	350
SDH2HHTH(T)	200			700	450
SDH3HHTH(T)	300			800	550
SDH4HHTH(T)	400		200	1000	700
SDH5HHTH(T)	500			1100	800
SDH6HHTH(T)	600			1200	900
SDH7HHTH(T)	700			1300	1000
SDH8HHTH(T)	800		300	1600	1200
SDH9HHTH(T)	900			1700	1300
SDH0HHTH(T)	1000			1800	1400

# 密閉型水平 X 型線槽 (HORIZONTAL CROSS)

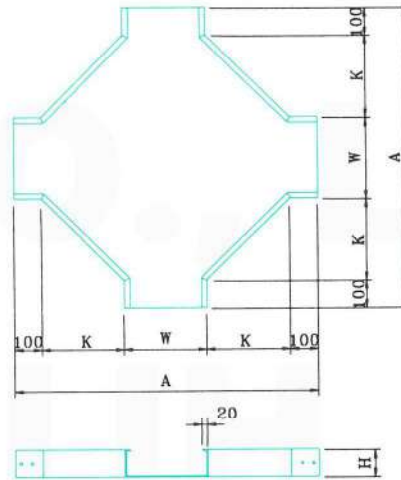
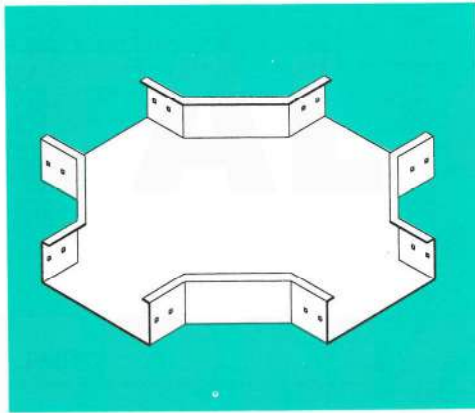

材 質：1.鋁合金 AA5052H32 或 AA1050H14 2.熱軋鐵板(JIS G3131)  
 3.鍍鋅鐵板(JIS 3302) 4.不銹鋼(SUS304) (SUS316)  
 表面處理：1.(鋁)陽極處理(10 $\mu$ ) 2.電著塗裝(17 $\mu$ )  
 3.(鐵)熱浸鍍鋅 (350g/m<sup>2</sup>) 4.靜電粉體塗裝(50 $\mu$ )  
 ※其他特殊規格亦可接受訂購

MATERIAL：1.ALUMINUM ALLOY AA5052H32 OR AA1050H14  
 2.HOT ROLL STEEL SHEET (JIS G3131)  
 3.GALVANIZED STEEL SHEET (JIS 3302)  
 4.STAINLESS STEEL (SUS304) OR (SUS316)

F I N I S H：1.ANODIC OXIDATION (10 $\mu$ )  
 2.ELECTRODEPOSITING COATING AFTER ANODIC OXIDATION (17 $\mu$ )  
 3.HOT DIP GALVANIZED AFTER FABRICATION (350g/m<sup>2</sup>)  
 4.POWDER COATING (50 $\mu$ )

※OTHER SIZES(WIDTHS) CAN BE ORDERED

邊槽高度 100H 系列 (100mm HEIGHT SERIES) 厚度 (T)=1.6mm or 2mm

(Units:mm)

邊槽各部尺寸圖	型 號 CAT.NO	線槽寬度 W	邊槽高度 H	斜邊長度 K	總 長 A
	SDC1HXH(T)	100	100	150	600
	SDC2HXH(T)	200			700
	SDC3HXH(T)	300			800
	SDC4HXH(T)	400		200	1000
	SDC5HXH(T)	500			1100
	SDC6HXH(T)	600			1200
	SDC7HXH(T)	700			1300
	SDC8HXH(T)	800		300	1600
	SDC9HXH(T)	900			1700
	SDC0HXH(T)	1000			1800

邊槽高度 150H 系列 (150mm HEIGHT SERIES) 厚度 (T)=2mm or 2.6mm

(Units:mm)

邊槽各部尺寸圖	型 號 CAT.NO	線槽寬度 W	邊槽高度 H	斜邊長度 K	總 長 A
	SDE1HXH(T)	100	150	150	600
	SDE2HXH(T)	200			700
	SDE3HXH(T)	300			800
	SDE4HXH(T)	400		200	1000
	SDE5HXH(T)	500			1100
	SDE6HXH(T)	600			1200
	SDE7HXH(T)	700			1300
	SDE8HXH(T)	800		300	1600
	SDE9HXH(T)	900			1700
	SDE0HXH(T)	1000			1800

邊槽高度 200H 系列 (200mm HEIGHT SERIES) 厚度 (T)=2mm or 2.6mm

(Units:mm)

邊槽各部尺寸圖	型號 CAT NO	線槽寬度 W	邊槽高度 H	斜邊長度 K	總長 A	
	SDF1HXH(T)	100	200	150	600	
	SDF2HXH(T)	200			700	
	SDF3HXH(T)	300			800	
	SDF4HXH(T)	400		200	200	1000
	SDF5HXH(T)	500				1100
	SDF6HXH(T)	600				1200
	SDF7HXH(T)	700				1300
	SDF8HXH(T)	800		300	300	1600
	SDF9HXH(T)	900				1700
	SDF0HXH(T)	1000				1800

邊槽高度 250H 系列 (250mm HEIGHT SERIES) 厚度 (T)=2mm or 2.6mm

(Units:mm)

邊槽各部尺寸圖	型號 CAT NO	線槽寬度 W	邊槽高度 H	斜邊長度 K	總長 A	
	SDG1HXH(T)	100	250	150	600	
	SDG2HXH(T)	200			700	
	SDG3HXH(T)	300			800	
	SDG4HXH(T)	400		200	200	1000
	SDG5HXH(T)	500				1100
	SDG6HXH(T)	600				1200
	SDG7HXH(T)	700				1300
	SDG8HXH(T)	800		300	300	1600
	SDG9HXH(T)	900				1700
	SDG0HXH(T)	1000				1800

邊槽高度 300H 系列 (300mm HEIGHT SERIES) 厚度 (T)=2mm or 2.6mm

(Units:mm)

邊槽各部尺寸圖	型號 CAT NO	線槽寬度 W	邊槽高度 H	斜邊長度 K	總長 A	
	SDH1HXH(T)	100	300	150	600	
	SDH2HXH(T)	200			700	
	SDH3HXH(T)	300			800	
	SDH4HXH(T)	400		200	200	1000
	SDH5HXH(T)	500				1100
	SDH6HXH(T)	600				1200
	SDH7HXH(T)	700				1300
	SDH8HXH(T)	800		300	300	1600
	SDH9HXH(T)	900				1700
	SDH0HXH(T)	1000				1800

# 密閉型 90° 垂直上升線槽 (INSIDE VERTICAL 90°)

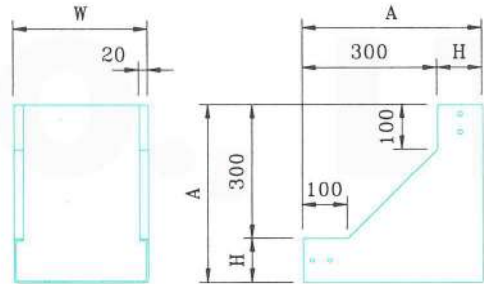
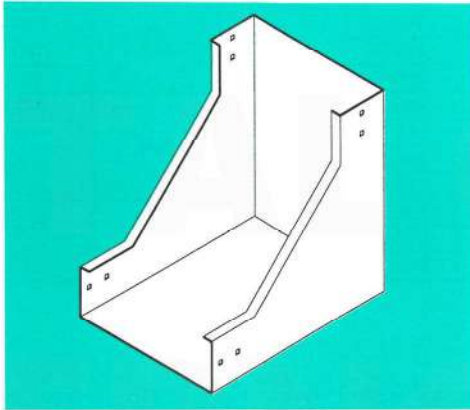

材 質：1.鋁合金 AA5052H32 或 AA1050H14 2.熱軋鐵板(JIS G3131)  
 3.鍍鋅鐵板(JIS 3302) 4.不銹鋼(SUS304)(SUS316)  
 表面處理：1.(鋁)陽極處理(10 $\mu$ ) 2.電著塗裝(17 $\mu$ )  
 3.(鐵)熱浸鍍鋅 (350g/m<sup>2</sup>) 4.靜電粉體塗裝(50 $\mu$ )  
 ※其他特殊規格亦可接受訂購

MATERIAL：1.ALUMINUM ALLOY AA5052H32 OR AA1050H14  
 2.HOT ROLL STEEL SHEET (JIS G3131)  
 3.GALVANIZED STEEL SHEET (JIS 3302)  
 4.STAINLESS STEEL (SUS304).OR (SUS316)

F I N I S H：1.ANODIC OXIDATION (10 $\mu$ )  
 2.ELECTRODEPOSITING COATING AFTER ANODIC OXIDATION (17 $\mu$ )  
 3.HOT DIP GALVANIZED AFTER FABRICATION (350g/m<sup>2</sup>)  
 4.POWDER COATING (50 $\mu$ )

※OTHER SIZES(WIDTHS) CAN BE ORDERED

邊槽高度 100H 系列 (100mm HEIGHT SERIES) 厚度 (T)=1.6mm or 2mm (Units:mm)

邊槽各部尺寸圖	型 號 CAT.NO	線槽寬度 W	邊槽高度 H	總 長 A
	SDC1IVH(T)	100	100	400
	SDC2IVH(T)	200		
	SDC3IVH(T)	300		
	SDC4IVH(T)	400		
	SDC5IVH(T)	500		
	SDC6IVH(T)	600		
	SDC7IVH(T)	700		
	SDC8IVH(T)	800		
	SDC9IVH(T)	900		
	SDC0IVH(T)	1000		

邊槽高度 150H 系列 (150mm HEIGHT SERIES) 厚度 (T)=2mm or 2.6mm (Units:mm)

邊槽各部尺寸圖	型 號 CAT.NO	線槽寬度 W	邊槽高度 H	總 長 A
	SDE1IVH(T)	100	150	450
	SDE2IVH(T)	200		
	SDE3IVH(T)	300		
	SDE4IVH(T)	400		
	SDE5IVH(T)	500		
	SDE6IVH(T)	600		
	SDE7IVH(T)	700		
	SDE8IVH(T)	800		
	SDE9IVH(T)	900		
	SDE0IVH(T)	1000		

邊槽高度 200H 系列 (200mm HEIGHT SERIES) 厚度 (T)=2mm or 2.6mm

(Units:mm)

邊槽各部尺寸圖	型號 CAT.NO	線槽寬度 W	邊槽高度 H	總長 A
	SDF1IVH(T)	100	200	500
	SDF2IVH(T)	200		
	SDF3IVH(T)	300		
	SDF4IVH(T)	400		
	SDF5IVH(T)	500		
	SDF6IVH(T)	600		
	SDF7IVH(T)	700		
	SDF8IVH(T)	800		
	SDF9IVH(T)	900		
	SDF0IVH(T)	1000		

邊槽高度 250H 系列 (250mm HEIGHT SERIES) 厚度 (T)=2mm or 2.6mm

(Units:mm)

邊槽各部尺寸圖	型號 CAT.NO	線槽寬度 W	邊槽高度 H	總長 A
	SDG1IVH(T)	100	250	550
	SDG2IVH(T)	200		
	SDG3IVH(T)	300		
	SDG4IVH(T)	400		
	SDG5IVH(T)	500		
	SDG6IVH(T)	600		
	SDG7IVH(T)	700		
	SDG8IVH(T)	800		
	SDG9IVH(T)	900		
	SDG0IVH(T)	1000		

邊槽高度 300H 系列 (300mm HEIGHT SERIES) 厚度 (T)=2mm or 2.6mm

(Units:mm)

邊槽各部尺寸圖	型號 CAT.NO	線槽寬度 W	邊槽高度 H	總長 A
	SDH1IVH(T)	100	300	600
	SDH2IVH(T)	200		
	SDH3IVH(T)	300		
	SDH4IVH(T)	400		
	SDH5IVH(T)	500		
	SDH6IVH(T)	600		
	SDH7IVH(T)	700		
	SDH8IVH(T)	800		
	SDH9IVH(T)	900		
	SDH0IVH(T)	1000		

# 密閉型 90° 垂直下降線槽 (OUTSIDE VERTICAL 90°)

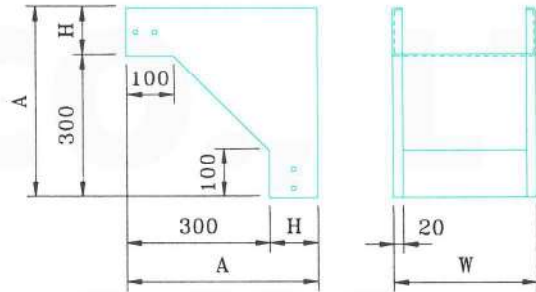
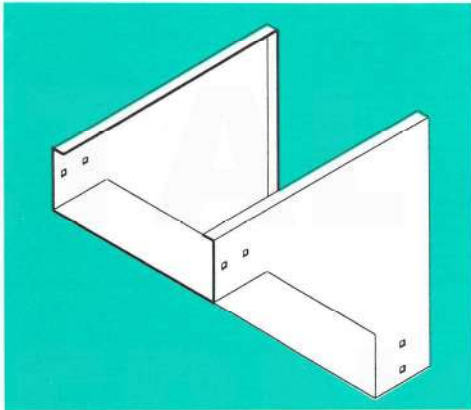

材 質：1.鋁合金 AA5052H32 或 AA1050H14 2.熱軋鐵板(JIS G3131)  
 3.鍍鋅鐵板(JIS 3302) 4.不銹鋼(SUS304) (SUS316)  
 表面處理：1.(鋁)陽極處理(10 $\mu$ ) 2.電著塗裝(17 $\mu$ )  
 3.(鐵)熱浸鍍鋅 (350g/m<sup>2</sup>) 4.靜電粉體塗裝(50 $\mu$ )  
 ※其他特殊規格亦可接受訂購

MATERIAL：1.ALUMINUM ALLOY AA5052H32 OR AA1050H14  
 2.HOT ROLL STEEL SHEET (JIS G3131)  
 3.GALVANIZED STEEL SHEET (JIS 3302)  
 4.STAINLESS STEEL (SUS304).OR (SUS316)

F I N I S H：1.ANODIC OXIDATION (10 $\mu$ )  
 2.ELECTRODEPOSITING COATING AFTER ANODIC OXIDATION (17 $\mu$ )  
 3.HOT DIP GALVANIZED AFTER FABRICATION (350g/m<sup>2</sup>)  
 4.POWDER COATING (50 $\mu$ )

※OTHER SIZES(WIDTHIS) CAN BE ORDERED

邊槽高度 100H 系列 (100mm HEIGHT SERIES) 厚度 (T)=1.6mm or 2mm (Units:mm)

邊槽各部尺寸圖	型 號 CAT.NO	線槽寬度 W	邊槽高度 H	總 長 A
	SDC10VH(T)	100	100	400
	SDC20VH(T)	200		
	SDC30VH(T)	300		
	SDC40VH(T)	400		
	SDC50VH(T)	500		
	SDC60VH(T)	600		
	SDC70VH(T)	700		
	SDC80VH(T)	800		
	SDC90VH(T)	900		
	SDC00VH(T)	1000		

邊槽高度 150H 系列 (150mm HEIGHT SERIES) 厚度 (T)=2mm or 2.6mm (Units:mm)

邊槽各部尺寸圖	型 號 CAT.NO	線槽寬度 W	邊槽高度 H	總 長 A
	SDE10VH(T)	100	150	450
	SDE20VH(T)	200		
	SDE30VH(T)	300		
	SDE40VH(T)	400		
	SDE50VH(T)	500		
	SDE60VH(T)	600		
	SDE70VH(T)	700		
	SDE80VH(T)	800		
	SDE90VH(T)	900		
	SDE00VH(T)	1000		

邊槽高度 200H 系列 (200mm HEIGHT SERIES) 厚度 (T)=2mm or 2.6mm

(Units:mm)

邊槽各部尺寸圖	型號 CAT.NO	線槽寬度 W	邊槽高度 H	總長 A
	SDF1OVH(T)	100	200	500
	SDF2OVH(T)	200		
	SDF3OVH(T)	300		
	SDF4OVH(T)	400		
	SDF5OVH(T)	500		
	SDF6OVH(T)	600		
	SDF7OVH(T)	700		
	SDF8OVH(T)	800		
	SDF9OVH(T)	900		
	SDF0OVH(T)	1000		

邊槽高度 250H 系列 (250mm HEIGHT SERIES) 厚度 (T)=2mm or 2.6mm

(Units:mm)

邊槽各部尺寸圖	型號 CAT.NO	線槽寬度 W	邊槽高度 H	總長 A
	SDG1OVH(T)	100	250	550
	SDG2OVH(T)	200		
	SDG3OVH(T)	300		
	SDG4OVH(T)	400		
	SDG5OVH(T)	500		
	SDG6OVH(T)	600		
	SDG7OVH(T)	700		
	SDG8OVH(T)	800		
	SDG9OVH(T)	900		
	SDG0OVH(T)	1000		

邊槽高度 300H 系列 (300mm HEIGHT SERIES) 厚度 (T)=2mm or 2.6mm

(Units:mm)

邊槽各部尺寸圖	型號 CAT.NO	線槽寬度 W	邊槽高度 H	總長 A
	SDH1OVH(T)	100	150	450
	SDH2OVH(T)	200		
	SDH3OVH(T)	300		
	SDH4OVH(T)	400		
	SDH5OVH(T)	500		
	SDH6OVH(T)	600		
	SDH7OVH(T)	700		
	SDH8OVH(T)	800		
	SDH9OVH(T)	900		
	SDH0OVH(T)	1000		

# 密閉型垂直 T 型線槽 (VERTICAL TEE)

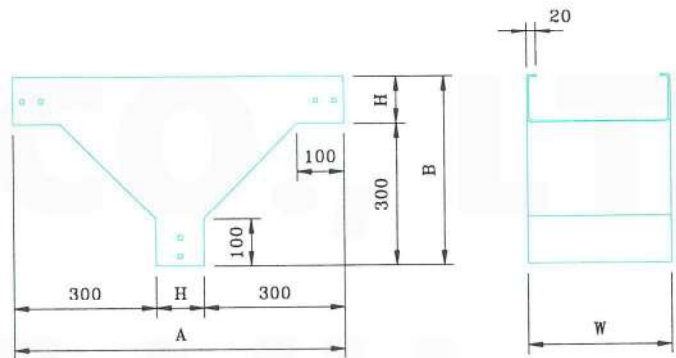
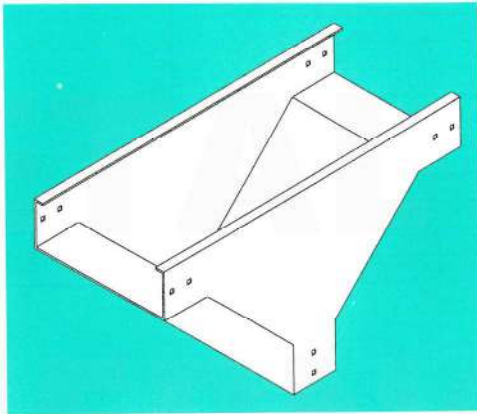

材 質：1.鋁合金 AA5052H32 或 AA1050H14 2.熱軋鐵板(JIS G3131)  
 3.鍍鋅鐵板(JIS 3302) 4.不銹鋼(SUS304) (SUS316)  
 表面處理：1.(鋁)陽極處理(10 $\mu$ ) 2.電著塗裝(17 $\mu$ )  
 3.(鐵)熱浸鍍鋅 (350g/m<sup>2</sup>) 4.靜電粉體塗裝(50 $\mu$ )  
 ※其他特殊規格亦可接受訂購

MATERIAL：1.ALUMINUM ALLOY AA5052H32 OR AA1050H14  
 2.HOT ROLL STEEL SHEET (JIS G3131)  
 3.GALVANIZED STEEL SHEET (JIS 3302)  
 4.STAINLESS STEEL (SUS304),OR (SUS316)

F I N I S H：1.ANODIC OXIDATION (10 $\mu$ )  
 2.ELECTRODEPOSITING COATING AFTER ANODIC OXIDATION (17 $\mu$ )  
 3.HOT DIP GALVANIZED AFTER FABRICATION (350g/m<sup>2</sup>)  
 4.POWDER COATING (50 $\mu$ )

※OTHER SIZES(WIDTHS) CAN BE ORDERED

邊槽高度 100H 系列 (100mm HEIGHT SERIES) 厚度 (T)=1.6mm or 2mm

(Units:mm)

邊槽各部尺寸圖	型 號 CAT NO	線槽寬度 W	邊槽高度 H	總 長 A	總 長 B
	SDC1VTH(T)	100	100	700	400
	SDC2VTH(T)	200			
	SDC3VTH(T)	300			
	SDC4VTH(T)	400			
	SDC5VTH(T)	500			
	SDC6VTH(T)	600			
	SDC7VTH(T)	700			
	SDC8VTH(T)	800			
	SDC9VTH(T)	900			
	SDC0VTH(T)	1000			

邊槽高度 150H 系列 (150mm HEIGHT SERIES) 厚度 (T)=2mm or 2.6mm

(Units:mm)

邊槽各部尺寸圖	型 號 CAT NO	線槽寬度 W	邊槽高度 H	總 長 A	總 長 B
	SDE1VTH(T)	100	150	750	450
	SDE2VTH(T)	200			
	SDE3VTH(T)	300			
	SDE4VTH(T)	400			
	SDE5VTH(T)	500			
	SDE6VTH(T)	600			
	SDE7VTH(T)	700			
	SDE8VTH(T)	800			
	SDE9VTH(T)	900			
	SDE0VTH(T)	1000			

邊槽高度 200H 系列 (200mm HEIGHT SERIES) 厚度 (T)=2mm or 2.6mm

(Units:mm)

邊槽各部尺寸圖	型號 CAT.NO	線槽寬度 W	邊槽高度 H	總長 A	總長 B
	SDF1VTH(T)	100	200	800	500
	SDF2VTH(T)	200			
	SDF3VTH(T)	300			
	SDF4VTH(T)	400			
	SDF5VTH(T)	500			
	SDF6VTH(T)	600			
	SDF7VTH(T)	700			
	SDF8VTH(T)	800			
	SDF9VTH(T)	900			
	SDF0VTH(T)	1000			

邊槽高度 250H 系列 (250mm HEIGHT SERIES) 厚度 (T)=2mm or 2.6mm

(Units:mm)

邊槽各部尺寸圖	型號 CAT.NO	線槽寬度 W	邊槽高度 H	總長 A	總長 B
	SDG1VTH(T)	100	250	850	550
	SDG2VTH(T)	200			
	SDG3VTH(T)	300			
	SDG4VTH(T)	400			
	SDG5VTH(T)	500			
	SDG6VTH(T)	600			
	SDG7VTH(T)	700			
	SDG8VTH(T)	800			
	SDG9VTH(T)	900			
	SDG0VTH(T)	1000			

邊槽高度 300H 系列 (300mm HEIGHT SERIES) 厚度 (T)=2mm or 2.6mm

(Units:mm)

邊槽各部尺寸圖	型號 CAT.NO	線槽寬度 W	邊槽高度 H	總長 A	總長 B
	SDH1VTH(T)	100	300	900	600
	SDH2VTH(T)	200			
	SDH3VTH(T)	300			
	SDH4VTH(T)	400			
	SDH5VTH(T)	500			
	SDH6VTH(T)	600			
	SDH7VTH(T)	700			
	SDH8VTH(T)	800			
	SDH9VTH(T)	900			
	SDH0VTH(T)	1000			

# 密閉中心型大小線槽 (BOTH SIDES REDUCER)

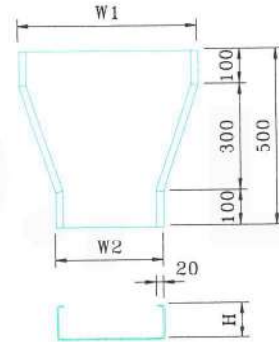
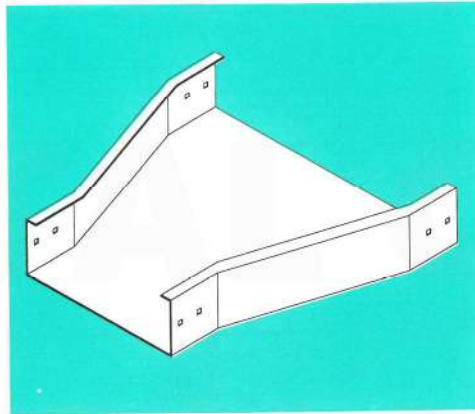

材 質：1.鋁合金 AA5052H32 或 AA1050H14 2.熱軋鐵板(JIS G3131)  
3.鍍鋅鐵板(JIS 3302) 4.不銹鋼(SUS304) (SUS316)  
表面處理：1.(鋁)陽極處理(10 $\mu$ ) 2.電著塗裝(17 $\mu$ )  
3.(鐵)熱浸鍍鋅 (350g/m<sup>2</sup>) 4.靜電粉體塗裝(50 $\mu$ )  
※其他特殊規格亦可接受訂購

MATERIAL: 1.ALUMINUM ALLOY AA5052H32 OR AA1050H14  
2.HOT ROLL STEEL SHEET (JIS G3131)  
3.GALVANIZED STEEL SHEET (JIS 3302)  
4.STAINLESS STEEL (SUS304).OR (SUS316)

F I N I S H : 1.ANODIC OXIDATION ( 10 $\mu$  )  
2.ELECTRODEPOSITING COATING AFTER ANODIC OXIDATION ( 17 $\mu$  )  
3.HOT DIP GALVANIZED AFTER FABRICATION ( 350g/m<sup>2</sup> )  
4.POWDER COATING ( 50 $\mu$  )

※OTHER SIZES(WIDTHS) CAN BE ORDERED

厚度(T)=1.6mm 2mm or 2.6mm

Units:mm

CAT.NO. W1-W2	H	100H	150H	200H	250H	300H
200-100		SDC21RCH(T)	SDE21RCH(T)	SDF21RCH(T)	SDG21RCH(T)	SDH21RCH(T)
300-200		SDC32RCH(T)	SDE32RCH(T)	SDF32RCH(T)	SDG32RCH(T)	SDH32RCH(T)
400-200		SDC42RCH(T)	SDE42RCH(T)	SDF42RCH(T)	SDG42RCH(T)	SDH42RCH(T)
400-300		SDC43RCH(T)	SDE43RCH(T)	SDF43RCH(T)	SDG43RCH(T)	SDH43RCH(T)
500-200		SDC52RCH(T)	SDE52RCH(T)	SDF52RCH(T)	SDG52RCH(T)	SDH52RCH(T)
500-300		SDC53RCH(T)	SDE53RCH(T)	SDF53RCH(T)	SDG53RCH(T)	SDH53RCH(T)
500-400		SDC54RCH(T)	SDE54RCH(T)	SDF54RCH(T)	SDG54RCH(T)	SDH54RCH(T)
600-200		SDC62RCH(T)	SDE62RCH(T)	SDF62RCH(T)	SDG62RCH(T)	SDH62RCH(T)
600-300		SDC63RCH(T)	SDE63RCH(T)	SDF63RCH(T)	SDG63RCH(T)	SDH63RCH(T)
600-400		SDC64RCH(T)	SDE64RCH(T)	SDF64RCH(T)	SDG64RCH(T)	SDH64RCH(T)
600-500		SDC65RCH(T)	SDE65RCH(T)	SDF65RCH(T)	SDG65RCH(T)	SDH65RCH(T)
700-300		SDC73RCH(T)	SDE73RCH(T)	SDF73RCH(T)	SDG73RCH(T)	SDH73RCH(T)
700-400		SDC74RCH(T)	SDE74RCH(T)	SDF74RCH(T)	SDG74RCH(T)	SDH74RCH(T)
700-500		SDC75RCH(T)	SDE75RCH(T)	SDF75RCH(T)	SDG75RCH(T)	SDH75RCH(T)
700-600		SDC76RCH(T)	SDE76RCH(T)	SDF76RCH(T)	SDG76RCH(T)	SDH76RCH(T)
800-300		SDC83RCH(T)	SDE83RCH(T)	SDF83RCH(T)	SDG83RCH(T)	SDH83RCH(T)
800-400		SDC84RCH(T)	SDE84RCH(T)	SDF84RCH(T)	SDG84RCH(T)	SDH84RCH(T)
800-500		SDC85RCH(T)	SDE85RCH(T)	SDF85RCH(T)	SDG85RCH(T)	SDH85RCH(T)
800-600		SDC86RCH(T)	SDE86RCH(T)	SDF86RCH(T)	SDG86RCH(T)	SDH86RCH(T)
800-700		SDC87RCH(T)	SDE87RCH(T)	SDF87RCH(T)	SDG87RCH(T)	SDH87RCH(T)
900-300		SDC93RCH(T)	SDE93RCH(T)	SDF93RCH(T)	SDG93RCH(T)	SDH93RCH(T)
900-400		SDC94RCH(T)	SDE94RCH(T)	SDF94RCH(T)	SDG94RCH(T)	SDH94RCH(T)
900-500		SDC95RCH(T)	SDE95RCH(T)	SDF95RCH(T)	SDG95RCH(T)	SDH95RCH(T)
900-600		SDC96RCH(T)	SDE96RCH(T)	SDF96RCH(T)	SDG96RCH(T)	SDH96RCH(T)
900-700		SDC97RCH(T)	SDE97RCH(T)	SDF97RCH(T)	SDG97RCH(T)	SDH97RCH(T)
900-800		SDC98RCH(T)	SDE98RCH(T)	SDF98RCH(T)	SDG98RCH(T)	SDH98RCH(T)
1000-300		SDC03RCH(T)	SDE03RCH(T)	SDF03RCH(T)	SDG03RCH(T)	SDH03RCH(T)
1000-400		SDC04RCH(T)	SDE04RCH(T)	SDF04RCH(T)	SDG04RCH(T)	SDH04RCH(T)
1000-500		SDC05RCH(T)	SDE05RCH(T)	SDF05RCH(T)	SDG05RCH(T)	SDH05RCH(T)
1000-600		SDC06RCH(T)	SDE06RCH(T)	SDF06RCH(T)	SDG06RCH(T)	SDH06RCH(T)
1000-700		SDC07RCH(T)	SDE07RCH(T)	SDF07RCH(T)	SDG07RCH(T)	SDH07RCH(T)
1000-800		SDC08RCH(T)	SDE08RCH(T)	SDF08RCH(T)	SDG08RCH(T)	SDH08RCH(T)
1000-900		SDC09RCH(T)	SDE09RCH(T)	SDF09RCH(T)	SDG09RCH(T)	SDH09RCH(T)

# 密閉左縮型大小線槽 (LEFT HAND REDUCER)

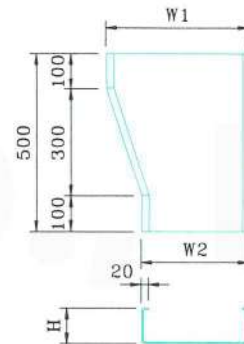
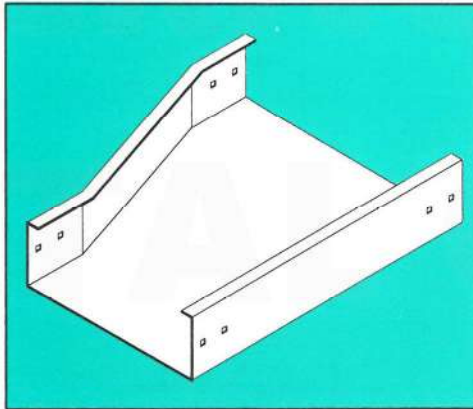

材 質：1.鋁合金 AA5052H32 或 AA1050H14 2.熱軋鐵板(JIS G3131)  
 3.鍍鋅鐵板(JIS 3302) 4.不銹鋼(SUS304) (SUS316)  
 表面處理：1.(鋁)陽極處理(10 $\mu$ ) 2.電著塗裝(17 $\mu$ )  
 3.(鐵)熱浸鍍鋅 (350g/m<sup>2</sup>) 4.靜電粉體塗裝(50 $\mu$ )  
 ※其他特殊規格亦可接受訂購

MATERIAL：1.ALUMINUM ALLOY AA5052H32 OR AA1050H14  
 2.HOT ROLL STEEL SHEET (JIS G3131)  
 3.GALVANIZED STEEL SHEET (JIS 3302)  
 4.STAINLESS STEEL (SUS304).OR (SUS316)

F I N I S H：1.ANODIC OXIDATION ( 10 $\mu$  )  
 2.ELECTRODEPOSITING COATING AFTER ANODIC OXIDATION ( 17 $\mu$  )  
 3.HOT DIP GALVANIZED AFTER FABRICATION ( 350g/m<sup>2</sup> )  
 4.POWDER COATING ( 50 $\mu$  )

※OTHER SIZES(WIDTHS) CAN BE ORDERED

厚度(T)=1.6mm 2mm or 2.6mm

Units:mm

CAT.NO. W1-W2	H	100H	150H	200H	250H	300H
200-100		SDC21RLH(T)	SDE21RLH(T)	SDF21RLH(T)	SDG21RLH(T)	SDH21RLH(T)
300-200		SDC32RLH(T)	SDE32RLH(T)	SDF32RLH(T)	SDG32RLH(T)	SDH32RLH(T)
400-200		SDC42RLH(T)	SDE42RLH(T)	SDF42RLH(T)	SDG42RLH(T)	SDH42RLH(T)
400-300		SDC43RLH(T)	SDE43RLH(T)	SDF43RLH(T)	SDG43RLH(T)	SDH43RLH(T)
500-200		SDC52RLH(T)	SDE52RLH(T)	SDF52RLH(T)	SDG52RLH(T)	SDH52RLH(T)
500-300		SDC53RLH(T)	SDE53RLH(T)	SDF53RLH(T)	SDG53RLH(T)	SDH53RLH(T)
500-400		SDC54RLH(T)	SDE54RLH(T)	SDF54RLH(T)	SDG54RLH(T)	SDH54RLH(T)
600-200		SDC62RLH(T)	SDE62RLH(T)	SDF62RLH(T)	SDG62RLH(T)	SDH62RLH(T)
600-300		SDC63RLH(T)	SDE63RLH(T)	SDF63RLH(T)	SDG63RLH(T)	SDH63RLH(T)
600-400		SDC64RLH(T)	SDE64RLH(T)	SDF64RLH(T)	SDG64RLH(T)	SDH64RLH(T)
600-500		SDC65RLH(T)	SDE65RLH(T)	SDF65RLH(T)	SDG65RLH(T)	SDH65RLH(T)
700-300		SDC73RLH(T)	SDE73RLH(T)	SDF73RLH(T)	SDG73RLH(T)	SDH73RLH(T)
700-400		SDC74RLH(T)	SDE74RLH(T)	SDF74RLH(T)	SDG74RLH(T)	SDH74RLH(T)
700-500		SDC75RLH(T)	SDE75RLH(T)	SDF75RLH(T)	SDG75RLH(T)	SDH75RLH(T)
700-600		SDC76RLH(T)	SDE76RLH(T)	SDF76RLH(T)	SDG76RLH(T)	SDH76RLH(T)
800-300		SDC83RLH(T)	SDE83RLH(T)	SDF83RLH(T)	SDG83RLH(T)	SDH83RLH(T)
800-400		SDC84RLH(T)	SDE84RLH(T)	SDF84RLH(T)	SDG84RLH(T)	SDH84RLH(T)
800-500		SDC85RLH(T)	SDE85RLH(T)	SDF85RLH(T)	SDG85RLH(T)	SDH85RLH(T)
800-600		SDC86RLH(T)	SDE86RLH(T)	SDF86RLH(T)	SDG86RLH(T)	SDH86RLH(T)
800-700		SDC87RLH(T)	SDE87RLH(T)	SDF87RLH(T)	SDG87RLH(T)	SDH87RLH(T)
900-300		SDC93RLH(T)	SDE93RLH(T)	SDF93RLH(T)	SDG93RLH(T)	SDH93RLH(T)
900-400		SDC94RLH(T)	SDE94RLH(T)	SDF94RLH(T)	SDG94RLH(T)	SDH94RLH(T)
900-500		SDC95RLH(T)	SDE95RLH(T)	SDF95RLH(T)	SDG95RLH(T)	SDH95RLH(T)
900-600		SDC96RLH(T)	SDE96RLH(T)	SDF96RLH(T)	SDG96RLH(T)	SDH96RLH(T)
900-700		SDC97RLH(T)	SDE97RLH(T)	SDF97RLH(T)	SDG97RLH(T)	SDH97RLH(T)
900-800		SDC98RLH(T)	SDE98RLH(T)	SDF98RLH(T)	SDG98RLH(T)	SDH98RLH(T)
1000-300		SDC03RLH(T)	SDE03RLH(T)	SDF03RLH(T)	SDG03RLH(T)	SDH03RLH(T)
1000-400		SDC04RLH(T)	SDE04RLH(T)	SDF04RLH(T)	SDG04RLH(T)	SDH04RLH(T)
1000-500		SDC05RLH(T)	SDE05RLH(T)	SDF05RLH(T)	SDG05RLH(T)	SDH05RLH(T)
1000-600		SDC06RLH(T)	SDE06RLH(T)	SDF06RLH(T)	SDG06RLH(T)	SDH06RLH(T)
1000-700		SDC07RLH(T)	SDE07RLH(T)	SDF07RLH(T)	SDG07RLH(T)	SDH07RLH(T)
1000-800		SDC08RLH(T)	SDE08RLH(T)	SDF08RLH(T)	SDG08RLH(T)	SDH08RLH(T)
1000-900		SDC09RLH(T)	SDE09RLH(T)	SDF09RLH(T)	SDG09RLH(T)	SDH09RLH(T)

# 密閉右縮型大小線槽 (RIGHT HAND REDUCER)

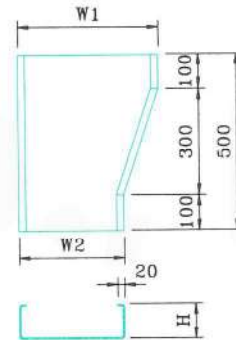
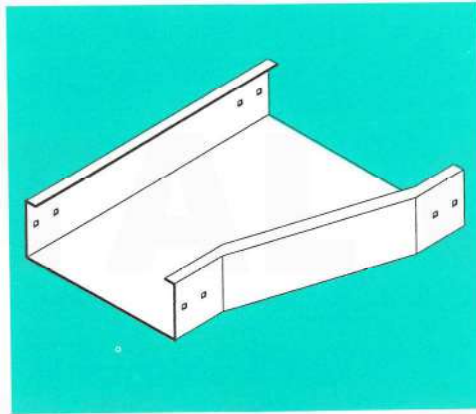

材 質：1.鋁合金 AA5052H32 或 AA1050H14 2.熱軋鐵板(JIS G3131)  
3.鍍鋅鐵板(JIS 3302) 4.不銹鋼(SUS304) (SUS316)  
表面處理：1.(鋁)陽極處理(10 $\mu$ ) 2.電著塗裝(17 $\mu$ )  
3.(鐵)熱浸鍍鋅 (350g/m<sup>2</sup>) 4.靜電粉體塗裝(50 $\mu$ )  
※其他特殊規格亦可接受訂購

MATERIAL：1.ALUMINUM ALLOY AA5052H32 OR AA1050H14  
2.HOT ROLL STEEL SHEET (JIS G3131)  
3.GALVANIZED STEEL SHEET (JIS 3302)  
4.STAINLESS STEEL (SUS304).OR (SUS316)

F I N I S H：1.ANODIC OXIDATION ( 10 $\mu$  )  
2.ELECTRODEPOSITING COATING AFTER ANODIC OXIDATION ( 17 $\mu$  )  
3.HOT DIP GALVANIZED AFTER FABRICATION ( 350g/m<sup>2</sup> )  
4.POWDER COATING ( 50 $\mu$  )

※OTHER SIZES(WIDTHS) CANBE TO ORDER

厚度(T)=1.6mm 2mm or 2.6mm

Units:mm

CAT.NO. W1-W2	H 100H	150H	200H	250H	300H
200-100	SDC21RRH(T)	SDE21RRH(T)	SDF21RRH(T)	SDG21RRH(T)	SDH21RRH(T)
300-200	SDC32RRH(T)	SDE32RRH(T)	SDF32RRH(T)	SDG32RRH(T)	SDH32RRH(T)
400-200	SDC42RRH(T)	SDE42RRH(T)	SDF42RRH(T)	SDG42RRH(T)	SDH42RRH(T)
400-300	SDC43RRH(T)	SDE43RRH(T)	SDF43RRH(T)	SDG43RRH(T)	SDH43RRH(T)
500-200	SDC52RRH(T)	SDE52RRH(T)	SDF52RRH(T)	SDG52RRH(T)	SDH52RRH(T)
500-300	SDC53RRH(T)	SDE53RRH(T)	SDF53RRH(T)	SDG53RRH(T)	SDH53RRH(T)
500-400	SDC54RRH(T)	SDE54RRH(T)	SDF54RRH(T)	SDG54RRH(T)	SDH54RRH(T)
600-200	SDC62RRH(T)	SDE62RRH(T)	SDF62RRH(T)	SDG62RRH(T)	SDH62RRH(T)
600-300	SDC63RRH(T)	SDE63RRH(T)	SDF63RRH(T)	SDG63RRH(T)	SDH63RRH(T)
600-400	SDC64RRH(T)	SDE64RRH(T)	SDF64RRH(T)	SDG64RRH(T)	SDH64RRH(T)
600-500	SDC65RRH(T)	SDE65RRH(T)	SDF65RRH(T)	SDG65RRH(T)	SDH65RRH(T)
700-300	SDC73RRH(T)	SDE73RRH(T)	SDF73RRH(T)	SDG73RRH(T)	SDH73RRH(T)
700-400	SDC74RRH(T)	SDE74RRH(T)	SDF74RRH(T)	SDG74RRH(T)	SDH74RRH(T)
700-500	SDC75RRH(T)	SDE75RRH(T)	SDF75RRH(T)	SDG75RRH(T)	SDH75RRH(T)
700-600	SDC76RRH(T)	SDE76RRH(T)	SDF76RRH(T)	SDG76RRH(T)	SDH76RRH(T)
800-300	SDC83RRH(T)	SDE83RRH(T)	SDF83RRH(T)	SDG83RRH(T)	SDH83RRH(T)
800-400	SDC84RRH(T)	SDE84RRH(T)	SDF84RRH(T)	SDG84RRH(T)	SDH84RRH(T)
800-500	SDC85RRH(T)	SDE85RRH(T)	SDF85RRH(T)	SDG85RRH(T)	SDH85RRH(T)
800-600	SDC86RRH(T)	SDE86RRH(T)	SDF86RRH(T)	SDG86RRH(T)	SDH86RRH(T)
800-700	SDC87RRH(T)	SDE87RRH(T)	SDF87RRH(T)	SDG87RRH(T)	SDH87RRH(T)
900-300	SDC93RRH(T)	SDE93RRH(T)	SDF93RRH(T)	SDG93RRH(T)	SDH93RRH(T)
900-400	SDC94RRH(T)	SDE94RRH(T)	SDF94RRH(T)	SDG94RRH(T)	SDH94RRH(T)
900-500	SDC95RRH(T)	SDE95RRH(T)	SDF95RRH(T)	SDG95RRH(T)	SDH95RRH(T)
900-600	SDC96RRH(T)	SDE96RRH(T)	SDF96RRH(T)	SDG96RRH(T)	SDH96RRH(T)
900-700	SDC97RRH(T)	SDE97RRH(T)	SDF97RRH(T)	SDG97RRH(T)	SDH97RRH(T)
900-800	SDC98RRH(T)	SDE98RRH(T)	SDF98RRH(T)	SDG98RRH(T)	SDH98RRH(T)
1000-300	SDC03RRH(T)	SDE03RRH(T)	SDF03RRH(T)	SDG03RRH(T)	SDH03RRH(T)
1000-400	SDC04RRH(T)	SDE04RRH(T)	SDF04RRH(T)	SDG04RRH(T)	SDH04RRH(T)
1000-500	SDC05RRH(T)	SDE05RRH(T)	SDF05RRH(T)	SDG05RRH(T)	SDH05RRH(T)
1000-600	SDC06RRH(T)	SDE06RRH(T)	SDF06RRH(T)	SDG06RRH(T)	SDH06RRH(T)
1000-700	SDC07RRH(T)	SDE07RRH(T)	SDF07RRH(T)	SDG07RRH(T)	SDH07RRH(T)
1000-800	SDC08RRH(T)	SDE08RRH(T)	SDF08RRH(T)	SDG08RRH(T)	SDH08RRH(T)
1000-900	SDC09RRH(T)	SDE09RRH(T)	SDF09RRH(T)	SDG09RRH(T)	SDH09RRH(T)

## 直式電纜線槽蓋板 (STRAIGHT TYPE COVER)

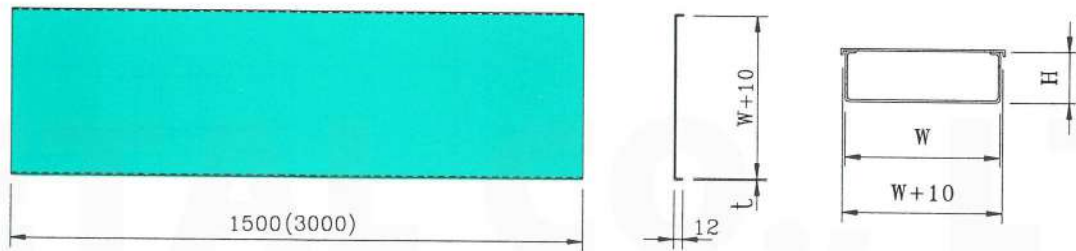

材 質：1.鋁合金 AA5052H32 或 AA1050H14 2.熱軋鐵板(JIS G3131)  
3.鍍鋅鐵板(JIS 3302) 4.不銹鋼(SUS304) (SUS316)  
表面處理：1.(鋁)陽極處理(10 $\mu$ ) 2.電著塗裝(17 $\mu$ )  
3.(鐵)熱浸鍍鋅 (350g/m<sup>2</sup>) 4.靜電粉體塗裝(50 $\mu$ )  
※其他特殊規格亦可接受訂購

MATERIAL：1.ALUMINUM ALLOY AA5052H32 OR AA1050H14  
2.HOT ROLL STEEL SHEET (JIS G3131)  
3.GALVANIZED STEEL SHEET (JIS 3302)  
4.STAINLESS STEEL (SUS304).OR (SUS316)

F I N I S H：1.ANODIC OXIDATION (10 $\mu$ )  
2.ELECTRODEPOSITING COATING AFTER ANODIC  
OXIDATION (17 $\mu$ )  
3.HOT DIP GALVANIZED AFTER FABRICATION (350g/m<sup>2</sup>)  
4.POWDER COATING (50 $\mu$ )

※OTHER SIZES(WIDTHS) CAN BE ORDERED

Units:mm

型號 CAT.NO	線架寬度 W	厚度 t
SF1SH	100	2 (1.6)
SF2SH	200	
SF3SH	300	
SF4SH	400	
SF5SH	500	
SF6SH	600	
SF7SH	700	
SF8SH	800	
SF9SH	900	
SF0SH	1000	

## 水平 90° 線槽蓋板 (HORIZONTAL 90° COVER)

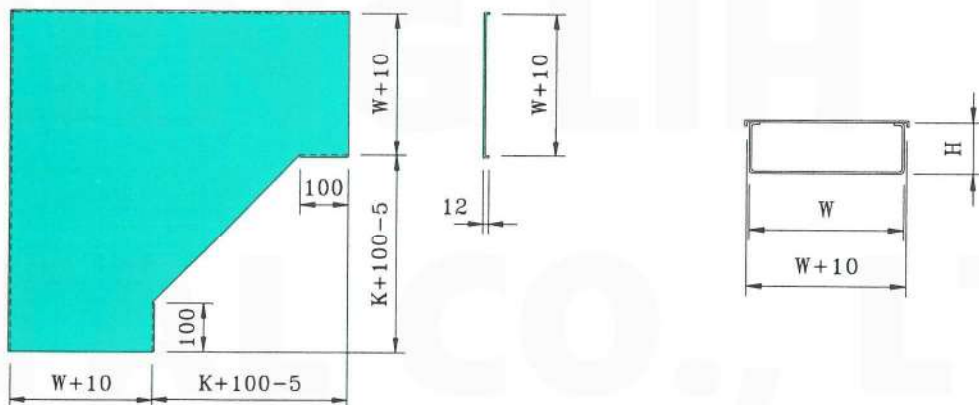

材 質：1.鋁合金 AA5052H32 或 AA1050H14 2.熱軋鐵板(JIS G3131)  
3.鍍鋅鐵板(JIS 3302) 4.不銹鋼(SUS304) (SUS316)  
表面處理：1.(鋁)陽極處理(10 $\mu$ ) 2.電著塗裝(17 $\mu$ )  
3.(鐵)熱浸鍍鋅 (350g/m<sup>2</sup>) 4.靜電粉體塗裝(50 $\mu$ )  
※其他特殊規格亦可接受訂購

MATERIAL：1.ALUMINUM ALLOY AA5052H32 OR AA1050H14  
2.HOT ROLL STEEL SHEET (JIS G3131)  
3.GALVANIZED STEEL SHEET (JIS 3302)  
4.STAINLESS STEEL (SUS304).OR (SUS316)

F I N I S H：1.ANODIC OXIDATION (10 $\mu$ )  
2.ELECTRODEPOSITING COATING AFTER ANODIC  
OXIDATION (17 $\mu$ )  
3.HOT DIP GALVANIZED AFTER FABRICATION (350g/m<sup>2</sup>)  
4.POWDER COATING (50 $\mu$ )

※OTHER SIZES(WIDTHS) CAN BE ORDERED

Units:mm

型號 CAT.NO	線架寬度 W	K	厚度 t
SF1HL9H	100	150	2 (1.6)
SF2HL9H	200		
SF3HL9H	300		
SF4HL9H	400	200	
SF5HL9H	500		
SF6HL9H	600		
SF7HL9H	700	300	
SF8HL9H	800		
SF9HL9H	900		
SF0HL9H	1000		

## 水平 T 型線槽蓋板 (HORIZONTAL TEE COVER)

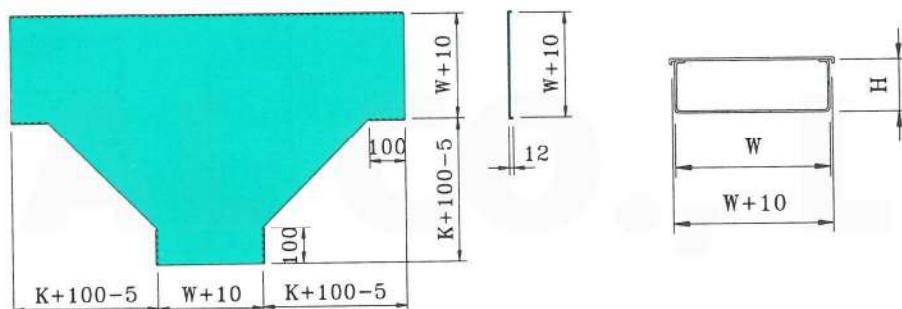

材 質：1.鋁合金 AA5052H32 或 AA1050H14 2.熱軋鐵板(JIS G3131)  
3.鍍鋅鐵板(JIS 3302) 4.不銹鋼(SUS304) (SUS316)  
表面處理：1.(鋁)陽極處理(10 $\mu$ ) 2.電著塗裝(17 $\mu$ )  
3.(鐵)熱浸鍍鋅 (350g/m<sup>2</sup>) 4.靜電粉體塗裝(50 $\mu$ )  
※其他特殊規格亦可接受訂購

MATERIAL: 1.ALUMINUM ALLOY AA5052H32 OR AA1050H14  
2.HOT ROLL STEEL SHEET (JIS G3131)  
3.GALVANIZED STEEL SHEET (JIS 3302)  
4.STAINLESS STEEL (SUS304).OR (SUS316)  
FINISH: 1.ANODIC OXIDATION (10 $\mu$ )  
2.ELECTRODEPOSITING COATING AFTER ANODIC OXIDATION (17 $\mu$ )  
3.HOT DIP GALVANIZED AFTER FABRICATION (350g/m<sup>2</sup>)  
4.POWDER COATING (50 $\mu$ )  
※OTHER SIZES(WIDTHS) CAN BE ORDERED

Units:mm			
型號 CAT.NO	線架寬度 W	K	厚度 t
SF1HTH	100	150	2 (1.6)
SF2HTH	200		
SF3HTH	300		
SF4HTH	400	200	
SF5HTH	500		
SF6HTH	600		
SF7HTH	700	300	
SF8HTH	800		
SF9HTH	900		
SF0HTH	1000		

## 水平 X 型線槽蓋板 (HORIZONTAL CROSS COVER)

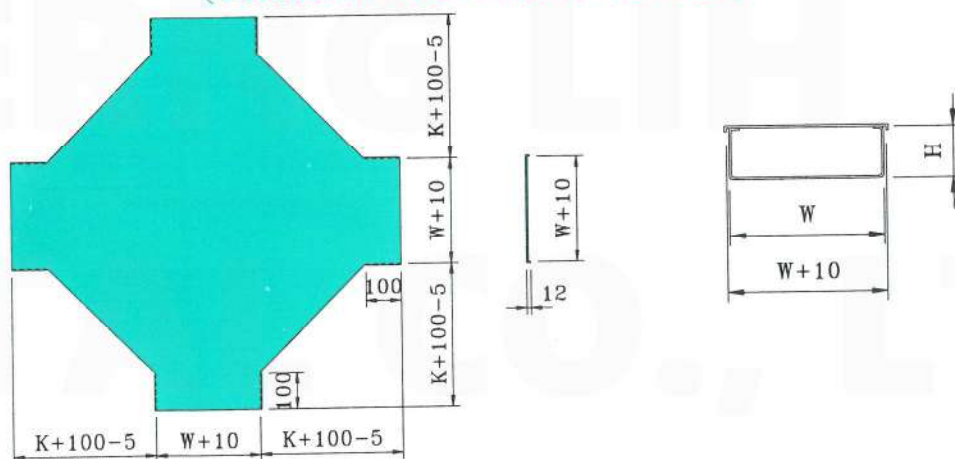

材 質：1.鋁合金 AA5052H32 或 AA1050H14 2.熱軋鐵板(JIS G3131)  
3.鍍鋅鐵板(JIS 3302) 4.不銹鋼(SUS304) (SUS316)  
表面處理：1.(鋁)陽極處理(10 $\mu$ ) 2.電著塗裝(17 $\mu$ )  
3.(鐵)熱浸鍍鋅 (350g/m<sup>2</sup>) 4.靜電粉體塗裝(50 $\mu$ )  
※其他特殊規格亦可接受訂購

MATERIAL: 1.ALUMINUM ALLOY AA5052H32 OR AA1050H14  
2.HOT ROLL STEEL SHEET (JIS G3131)  
3.GALVANIZED STEEL SHEET (JIS 3302)  
4.STAINLESS STEEL (SUS304).OR (SUS316)  
FINISH: 1.ANODIC OXIDATION (10 $\mu$ )  
2.ELECTRODEPOSITING COATING AFTER ANODIC OXIDATION (17 $\mu$ )  
3.HOT DIP GALVANIZED AFTER FABRICATION (350g/m<sup>2</sup>)  
4.POWDER COATING (50 $\mu$ )  
※OTHER SIZES(WIDTHS) CAN BE ORDERED

Units:mm			
型號 CAT.NO	線架寬度 W	K	厚度 t
SF1HXX	100	150	2 (1.6)
SF2HXX	200		
SF3HXX	300		
SF4HXX	400	200	
SF5HXX	500		
SF6HXX	600		
SF7HXX	700	300	
SF8HXX	800		
SF9HXX	900		
SF0HXX	1000		

## 90° 垂直上升線槽蓋板 (INSIDE VERTICAL 90° COVER)

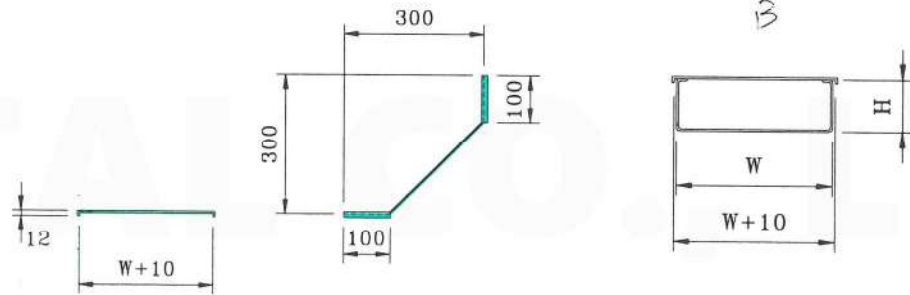

材 質：1.鋁合金 AA5052H32 或 AA1050H14 2.熱軋鐵板(JIS G3131)  
3.鍍鋅鐵板(JIS 3302) 4.不銹鋼(SUS304) (SUS316)  
表面處理：1.(鋁)陽極處理(10 $\mu$ ) 2.電著塗裝(17 $\mu$ )  
3.(鐵)熱浸鍍鋅 (350g/m<sup>2</sup>) 4.靜電粉體塗裝(50 $\mu$ )  
※其他特殊規格亦可接受訂購

MATERIAL：1.ALUMINUM ALLOY AA5052H32 OR AA1050H14  
2.HOT ROLL STEEL SHEET (JIS G3131)  
3.GALVANIZED STEEL SHEET (JIS 3302)  
4.STAINLESS STEEL (SUS304).OR (SUS316)

FINISH：1.ANODIC OXIDATION (10 $\mu$ )  
2.ELECTRODEPOSITING COATING AFTER ANODIC OXIDATION (17 $\mu$ )  
3.HOT DIP GALVANIZED AFTER FABRICATION (350g/m<sup>2</sup>)  
4.POWDER COATING (50 $\mu$ )  
※OTHER SIZES(WIDTHS) CAN BE ORDERED

Units:mm			
型號 CAT.NO	線架寬度 W	厚度 t	
SF11V9H	100	2 (1.6)	
SF21V9H	200		
SF31V9H	300		
SF41V9H	400		
SF51V9H	500		
SF61V9H	600		
SF71V9H	700		
SF81V9H	800		
SF91V9H	900		
SF01V9H	1000		

## 90° 垂直下降線槽蓋板 (OUTSIDE VERTICAL 90° COVER)

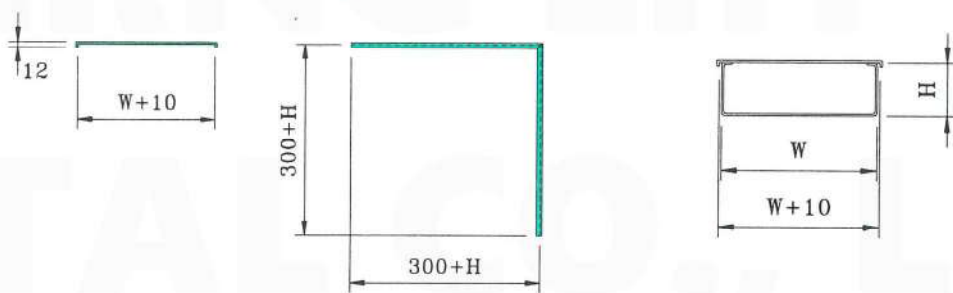

材 質：1.鋁合金 AA5052H32 或 AA1050H14 2.熱軋鐵板(JIS G3131)  
3.鍍鋅鐵板(JIS 3302) 4.不銹鋼(SUS304) (SUS316)  
表面處理：1.(鋁)陽極處理(10 $\mu$ ) 2.電著塗裝(17 $\mu$ )  
3.(鐵)熱浸鍍鋅 (350g/m<sup>2</sup>) 4.靜電粉體塗裝(50 $\mu$ )  
※其他特殊規格亦可接受訂購

MATERIAL：1.ALUMINUM ALLOY AA5052H32 OR AA1050H14  
2.HOT ROLL STEEL SHEET (JIS G3131)  
3.GALVANIZED STEEL SHEET (JIS 3302)  
4.STAINLESS STEEL (SUS304).OR (SUS316)

FINISH：1.ANODIC OXIDATION (10 $\mu$ )  
2.ELECTRODEPOSITING COATING AFTER ANODIC OXIDATION (17 $\mu$ )  
3.HOT DIP GALVANIZED AFTER FABRICATION (350g/m<sup>2</sup>)  
4.POWDER COATING (50 $\mu$ )  
※OTHER SIZES(WIDTHS) CAN BE ORDERED

Units:mm			
型號 CAT.NO	線架寬度 W	高度 H	厚度 t
SF10V9H	100	2 (1.6)	
SF20V9H	200		
SF30V9H	300		
SF40V9H	400		
SF50V9H	500		
SF60V9H	600		
SF70V9H	700		
SF80V9H	800		
SF90V9H	900		
SF00V9H	1000		

## 中心型大小線槽蓋板 (BOTH SIDES REDUCER COVER)

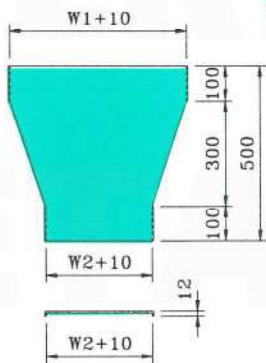

材 質：1.鋁合金 AA5052H32 或 AA1050H14 2.熱軋鐵板(JIS G3131)  
3.鍍鋅鐵板(JIS 3302) 4.不銹鋼(SUS304) (SUS316)  
表面處理：1.(鋁)陽極處理(10 $\mu$ ) 2.電著塗裝(17 $\mu$ )  
3.(鐵)熱浸鍍鋅 (350g/m<sup>2</sup>) 4.靜電粉體塗裝(50 $\mu$ )

MATERIAL: 1.ALUMINUM ALLOY AA5052H32 OR AA1050H14  
2.HOT ROLL STEEL SHEET (JIS G3131)  
3.GALVANIZED STEEL SHEET (JIS 3302)  
4.STAINLESS STEEL (SUS304).OR (SUS316)

FINISH: 1.ANODIC OXIDATION (10 $\mu$ )  
2.ELECTRODEPOSITING COATING AFTER ANODIC OXIDATION (17 $\mu$ )  
3.HOT DIP GALVANIZED AFTER FABRICATION (350g/m<sup>2</sup>)  
4.POWDER COATING (50 $\mu$ )

Units:mm

CAT.NO.	W1	W2	t	CAT.NO.	W1	W2	t
SF21RCH	200	100	2 (1.6)	SF85RCH	800	500	2 (1.6)
SF32RCH	300	200		SF86RCH	800	600	
SF42RCH	400	200		SF87RCH	800	700	
SF43RCH	400	300		SF93RCH	900	300	
SF52RCH	500	200		SF94RCH	900	400	
SF53RCH	500	300		SF95RCH	900	500	
SF54RCH	500	400		SF96RCH	900	600	
SF62RCH	600	200		SF97RCH	900	700	
SF63RCH	600	300		SF98RCH	900	800	
SF64RCH	600	400		SF03RCH	1000	300	
SF65RCH	600	500		SF04RCH	1000	400	
SF73RCH	700	300		SF05RCH	1000	500	
SF74RCH	700	400		SF06RCH	1000	600	
SF75RCH	700	500		SF07RCH	1000	700	
SF76RCH	700	600		SF08RCH	1000	800	
SF83RCH	800	300		SF09RCH	1000	900	
SF84RCH	800	400					

## 左縮型大小線槽蓋板 (LEFT HAND REDUCER COVER)

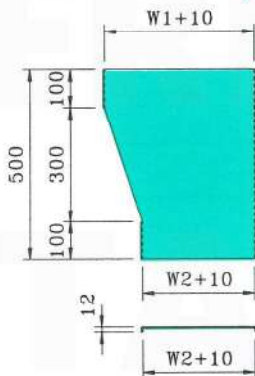

材 質：1.鋁合金 AA5052H32 或 AA1050H14 2.熱軋鐵板(JIS G3131)  
3.鍍鋅鐵板(JIS 3302) 4.不銹鋼(SUS304) (SUS316)  
表面處理：1.(鋁)陽極處理(10 $\mu$ ) 2.電著塗裝(17 $\mu$ )  
3.(鐵)熱浸鍍鋅 (350g/m<sup>2</sup>) 4.靜電粉體塗裝(50 $\mu$ )

MATERIAL: 1.ALUMINUM ALLOY AA5052H32 OR AA1050H14  
2.HOT ROLL STEEL SHEET (JIS G3131)  
3.GALVANIZED STEEL SHEET (JIS 3302)  
4.STAINLESS STEEL (SUS304).OR (SUS316)

FINISH: 1.ANODIC OXIDATION (10 $\mu$ )  
2.ELECTRODEPOSITING COATING AFTER ANODIC OXIDATION (17 $\mu$ )  
3.HOT DIP GALVANIZED AFTER FABRICATION (350g/m<sup>2</sup>)  
4.POWDER COATING (50 $\mu$ )

Units:mm

CAT.NO.	W1	W2	t	CAT.NO.	W1	W2	t
SF21RLH	200	100	2 (1.6)	SF85RLH	800	500	2 (1.6)
SF32RLH	300	200		SF86RLH	800	600	
SF42RLH	400	200		SF87RLH	800	700	
SF43RLH	400	300		SF93RLH	900	300	
SF52RLH	500	200		SF94RLH	900	400	
SF53RLH	500	300		SF95RLH	900	500	
SF54RLH	500	400		SF96RLH	900	600	
SF62RLH	600	200		SF97RLH	900	700	
SF63RLH	600	300		SF98RLH	900	800	
SF64RLH	600	400		SF03RLH	1000	300	
SF65RLH	600	500		SF04RLH	1000	400	
SF73RLH	700	300		SF05RLH	1000	500	
SF74RLH	700	400		SF06RLH	1000	600	
SF75RLH	700	500		SF07RLH	1000	700	
SF76RLH	700	600		SF08RLH	1000	800	
SF83RLH	800	300		SF09RLH	1000	900	
SF84RLH	800	400					

## 右縮型大小線槽蓋板 (RIGHT HAND REDUCER COVER)

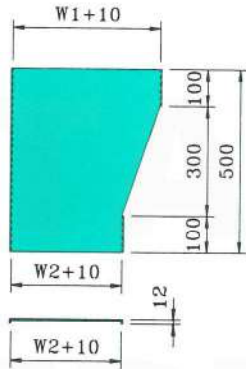

材 質：1.鋁合金 AA5052H32 或 AA1050H14 2.熱軋鐵板(JIS G3131)  
 3.鍍鋅鐵板(JIS 3302) 4.不銹鋼(SUS304) (SUS316)  
 表面處理：1.(鋁)陽極處理(10 $\mu$ ) 2.電著塗裝(17 $\mu$ )  
 3.(鐵)熱浸鍍鋅 (350g/m<sup>2</sup>) 4.靜電粉體塗裝(50 $\mu$ )  
 ※其他特殊規格亦可接受訂購

MATERIAL : 1.ALUMINUM ALLOY AA5052H32 OR AA1050H14  
 2.HOT ROLL STEEL SHEET (JIS G3131)  
 3.GALVANIZED STEEL SHEET (JIS 3302)  
 4.STAINLESS STEEL (SUS304) OR (SUS316)  
 FINISH : 1.ANODIC OXIDATION ( 10 $\mu$  )  
 2.ELECTRODEPOSITING COATING AFTER ANODIC OXIDATION ( 17 $\mu$  )  
 3.HOT DIP GALVANIZED AFTER FABRICATION ( 350g/m<sup>2</sup> )  
 4.POWDER COATING ( 50 $\mu$  )  
 ※OTHER SIZES(WIDTHS) CAN BE ORDERED

Units:mm

CAT.NO.	W1	W2	t	CAT.NO.	W1	W2	t
SF21RRH	200	100	2 (1.6)	SF85RRH	800	500	2 (1.6)
SF32RRH	300	200		SF86RRH	800	600	
SF42RRH	400	200		SF87RRH	800	700	
SF43RRH	400	300		SF93RRH	900	300	
SF52RRH	500	200		SF94RRH	900	400	
SF53RRH	500	300		SF95RRH	900	500	
SF54RRH	500	400		SF96RRH	900	600	
SF62RRH	600	200		SF97RRH	900	700	
SF63RRH	600	300		SF98RRH	900	800	
SF64RRH	600	400		SF03RRH	1000	300	
SF65RRH	600	500		SF04RRH	1000	400	
SF73RRH	700	300		SF05RRH	1000	500	
SF74RRH	700	400		SF06RRH	1000	600	
SF75RRH	700	500		SF07RRH	1000	700	
SF76RRH	700	600		SF08RRH	1000	800	
SF83RRH	800	300		SF09RRH	1000	900	
SF84RRH	800	400					

# 配件型號說明表

(HOW TO ORDER)

例如：S      C      A      H  
           :      :      :      :  
           材      型      邊槽高度      表面處理  
           質      式                           ④  
           ①      ②      ③

代號說明：

材 質	A：鋁    S：熱軋鐵板    (4)：不銹鋼 304    (6)：不銹鋼 316    G：鍍鋅鐵板
型 式	C：直式連接片      P：配電盤連接片      BE：終端封板 RE：大小接連接片    CL：蓋板夾            CN：側邊蓋板夾 WT：三角型壁架      WU：輕載型壁架      DU：重載型壁架 HB：外側固定片      CS：直式分隔板      GP：終端護夾
邊槽高度	A：60H    B：80H    C：100H    D：120H E：150H    F：200H    G：250H    H：300H
表面處理	A：陽極處理    E：電著塗裝 H：熱浸鍍鋅    P：靜電粉體塗裝

ILLUSTRATION：

①MATERIAL	A：ALUMINUM                      S：HOT ROLL STEEL SHEET (4)：STAINLESS STEEL304      (6)：STAINLESS STEEL316 G：GALVANIZED STEEL SHEET
②TYPE	C：STRAIGHT CONNECTOR      P：PANNEL SPLICE PLATE BE：BLIND END COVER          RE：REDUCER PLATE CL：COVER CLMAP              CN：SIDE COVER CLMAP WT：3-BRACKETS                WU：U-BRACKETS DU：D-BRACKETS                HB：OUTSIDE HOLD DOWN CLAMP CS：STRAIGHT SEPARATOR      GP：SHAPE GAP PROTECTORS
③HEIGHT OF SIDE RAIL	A：60H    B：80H    C：100H    D：120H E：150H    F：200H    G：250H    H：300H
④FINISHES	A：ANODIC OXIDATION E：ELECTORDEPOSITED COATING AFTER ANODIC OXIDATION H：HOT DIP GALVANIZING AFTER FORMING P：POWDER COATING

# 直式連接片 (STRAIGHT CONNECTOR)

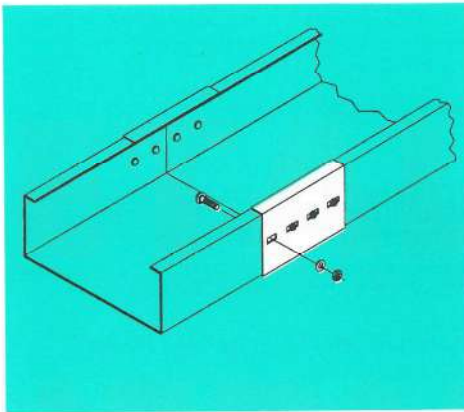

材 質：1.鋁合金 AA5052H32 或 AA1050H14 2.熱軋鐵板(JIS G3131)  
3.鍍鋅鐵板(JIS 3302) 4.不銹鋼(SUS304) (SUS316)  
表面處理：1.(鋁)陽極處理(10 $\mu$ ) 2.電著塗裝(17 $\mu$ )  
3.(鐵)熱浸鍍鋅 (350g/m<sup>2</sup>) 4.靜電粉體塗裝(50 $\mu$ )

MATERIAL：1.ALUMINUM ALLOY AA5052H32 OR AA1050H14  
2.HOT ROLL STEEL SHEET (JIS G3131)  
3.GALVANIZED STEEL SHEET (JIS 3302)  
4.STAINLESS STEEL (SUS304) OR (SUS316)

F I N I S H：1.ANODIC OXIDATION (10 $\mu$ )  
2.ELECTRODEPOSITING COATING AFTER ANODIC OXIDATION (17 $\mu$ )  
3.HOT DIP GALVANIZED AFTER FABRICATION (350g/m<sup>2</sup>)  
4.POWDER COATING (50 $\mu$ )

厚度 T=1.6mm or 2mm

(Units:mm)

適用線槽	CAT.NO.	適用線槽	CAT.NO.
60H 80H 100H	SCAH SCBH SCCH	120H 150H	SCDH SCEH
200H 250H	SCFH SCGH	300H	SCHH

# 配電盤連接片 ( PANNEL SPLICE PLATE )

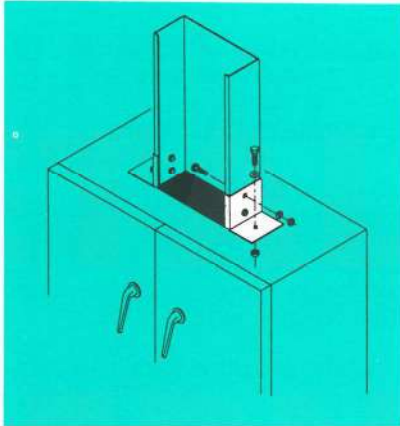

材 質：1.鋁合金 AA5052H32 或 AA1050H14 2.熱軋鐵板(JIS G3131)  
 3.鍍鋅鐵板(JIS 3302) 4.不銹鋼(SUS304) (SUS316)  
 表面處理：1.(鋁)陽極處理(10 $\mu$ ) 2.電著塗裝(17 $\mu$ )  
 3.(鐵)熱浸鍍鋅 (350g/m<sup>2</sup>) 4.靜電粉體塗裝(50 $\mu$ )

MATERIAL：1.ALUMINUM ALLOY AA5052H32 OR AA1050H14  
 2.HOT ROLL STEEL SHEET (JIS G3131)  
 3.GALVANIZED STEEL SHEET (JIS 3302)  
 4.STAINLESS STEEL (SUS304).OR (SUS316)

F I N I S H：1.ANODIC OXIDATION ( 10 $\mu$  )  
 2.ELECTRODEPOSITING COATING AFTER ANODIC OXIDATION ( 17 $\mu$  )  
 3.HOT DIP GALVANIZED AFTER FABRICATION ( 350g/m<sup>2</sup> )  
 4.POWDER COATING ( 50 $\mu$  )

厚度 T=1.6mm or 2mm

(Units:mm)

適用線槽	CAT.NO.	適用線槽	CAT.NO.
60H 80H 100H	SPAH SPBH SPCH	120H 150H	SPDH SPEH
200H 250H	SPFH SPGH	300H	SPHH

# 終端封板 (BLIND END COVER)

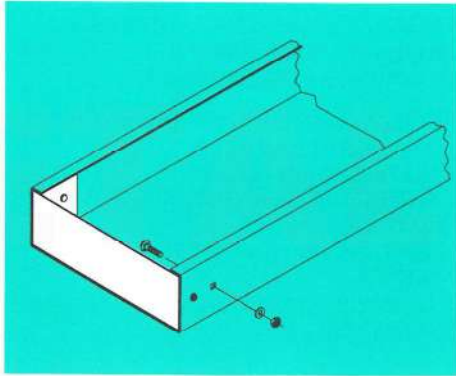

材 質：1.鋁合金 AA5052H32 或 AA1050H14 2.熱軋鐵板(JIS G3131)  
3.鍍鋅鐵板(JIS 3302) 4.不銹鋼(SUS304) (SUS316)

表面處理：1.(鋁)陽極處理(10 $\mu$ ) 2.電著塗裝(17 $\mu$ )  
3.(鐵)熱浸鍍鋅 (350g/m<sup>2</sup>) 4.靜電粉體塗裝(50 $\mu$ )

MATERIAL：1.ALUMINUM ALLOY AA5052H32 OR AA1050H14  
2.HOT ROLL STEEL SHEET (JIS G3131)  
3.GALVANIZED STEEL SHEET (JIS 3302)  
4.STAINLESS STEEL (SUS304).OR (SUS316)

FINISH：1.ANODIC OXIDATION (10 $\mu$ )  
2.ELECTRODEPOSITING COATING AFTER ANODIC OXIDATION (17 $\mu$ )  
3.HOT DIP GALVANIZED AFTER FABRICATION (350g/m<sup>2</sup>)  
4.POWDER COATING (50 $\mu$ )

厚度 T=1.6mm or 2mm

(Units:mm)

適用線槽		CAT.NO.		適用線槽		CAT.NO.	
60H 80H 100H	SBEAH SBEBH SBECH	W		120H 150H	SBEDH SBEEH	W	
<p>4-9x18 HOLES</p>		100		<p>6-9x18 HOLES</p>		100	
		200			200		
		300			300		
		400			400		
		500			500		
		600			600		
		700			700		
		800			800		
		900			900		
		1000			1000		
200H 250H	SBEFH SBEFH	W		300H	SBEHH	W	
<p>8-9x18 HOLES</p>		100		<p>12-9x18 HOLES</p>		100	
		200			200		
		300			300		
		400			400		
		500			500		
		600			600		
		700			700		
		800			800		
		900			900		
		1000			1000		

# 大小頭連接片 (REDUCER PLATE)

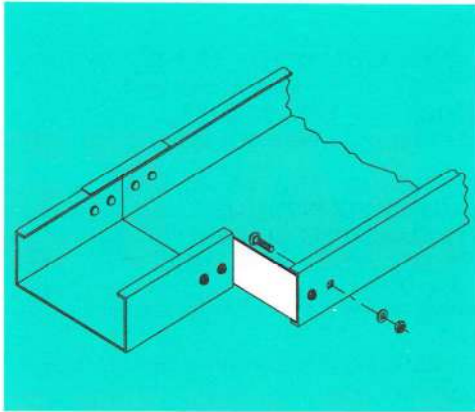

材 質：1.鋁合金 AA5052H32 或 AA1050H14 2.熱軋鐵板(JIS G3131)  
3.鍍鋅鐵板(JIS 3302) 4.不銹鋼(SUS304)(SUS316)  
表面處理：1.(鋁)陽極處理(10 $\mu$ ) 2.電著塗裝(17 $\mu$ )  
3.(鐵)熱浸鍍鋅 (350g/m<sup>2</sup>) 4.靜電粉體塗裝(50 $\mu$ )

MATERIAL: 1.ALUMINUM ALLOY AA5052H32 OR AA1050H14  
2.HOT ROLL STEEL SHEET (JIS G3131)  
3.GALVANIZED STEEL SHEET (JIS 3302)  
4.STAINLESS STEEL (SUS304).OR (SUS316)

F I N I S H : 1.ANODIC OXIDATION ( 10 $\mu$  )  
2.ELECTRODEPOSITING COATING AFTER ANODIC OXIDATION ( 17 $\mu$  )  
3.HOT DIP GALVANIZED AFTER FABRICATION ( 350g/m<sup>2</sup> )  
4.POWDER COATING ( 50 $\mu$  )

厚度 T=1.6mm or 2mm

(Units:mm)

適用線槽	CAT.NO.		適用線槽	CAT.NO.	
60H 80H 100H	SREAH SREBH SRECH	W	120H 150H	SREDH SREEH	W
		100			100
		200			200
		300			300
		400			400
		500			500
		600			600
		700			700
		800			800
		900			900
		1000			1000
200H 250H	SREFH SREGH	W	300H	SREHH	W
		100			100
		200			200
		300			300
		400			400
		500			500
		600			600
		700			700
		800			800
		900			900
		1000			1000

# 蓋板夾系列 (COVER CLAMP SERIES)

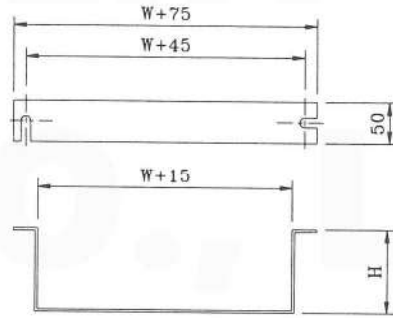
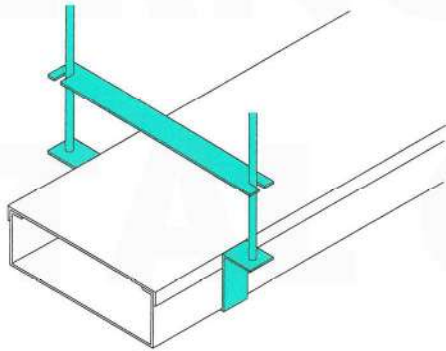

厚度 T=1.6mm or 2mm

Units:mm

蓋板夾 COVER CLAMP				
CAT.NO	W	H	材 質 MATERIAL	表面處理 FINISH
SCLH-01	100	60 (80) (100) (120) (150) (200) (250) (300)	鐵製(S) STEEL 不銹鋼製(4).(6) STAINLESS STEEL	(鐵)熱浸鍍鋅(H) HOT DIP GALVANIZED 靜電粉體塗裝(P) POWDER COATING
SCLH-02	200			
SCLH-03	300			
SCLH-04	400			
SCLH-05	500			
SCLH-06	600			
SCLH-07	700			
SCLH-08	800			
SCLH-09	900			
SCLH-10	1000			

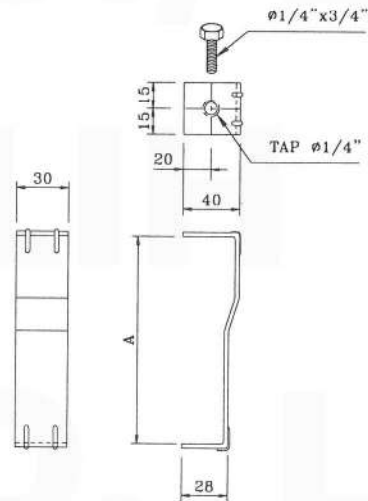
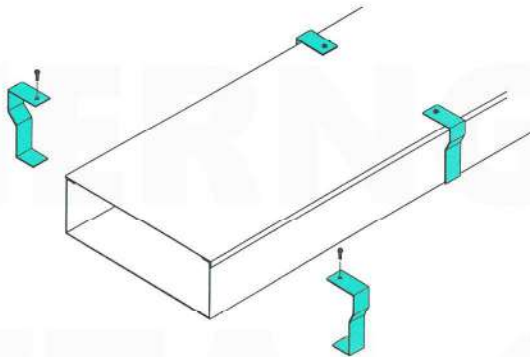

厚度 T=2mm

Units:mm

側邊蓋板夾 SIDE COVER CLAMP					
CAT.NO	H	A	材 質 MATERIAL	表面處理 FINISH	備 註
SCNAH	60	70	鐵製(S) STEEL 不銹鋼製(4).(6) STAINLESS STEEL	(鐵)熱浸鍍鋅(H) HOT DIP GALVANIZED 靜電粉體塗裝(P) POWDER COATING	附： 六角螺絲 1pc
SCNBH	80	90			
SCNCH	100	110			
SCNDH	120	130			
SCNEH	150	160			
SCNFH	200	210			
SCNGH	250	260			
SCNHH	300	310			

# 壁架系列 (WALL SUPPORT SERIES)

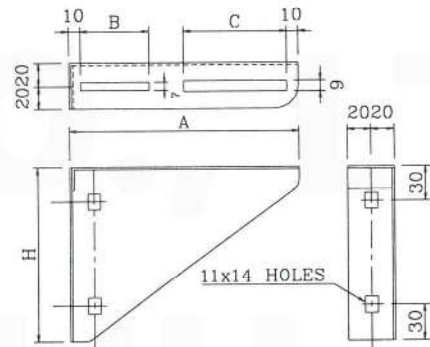
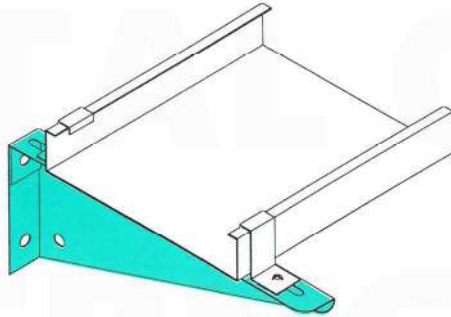

厚度 T=3mm

Units:mm

三角型壁架 3-BRACKETS							
CAT NO	W	A	B	C	H	材 質 MATERIAL	表面處理 FINISH
SWTH-01	100	200	60	90	150	鐵製(S) STEEL 不銹鋼製(4).(6) STAINLESS STEEL	(鐵)熱浸鍍鋅(H) HOT DIP GALVANIZED 靜電粉體塗裝(P) POWDER COATING
SWTH-02	200	300					
SWTH-03	300	400					
SWTH-04	400	500					
SWTH-05	500	600	75	180	200		
SWTH-06	600	700					
SWTH-07	700	800					
SWTH-08	800	900	80	360	250		
SWTH-09	900	1000					
SWTH-10	1000	1100					

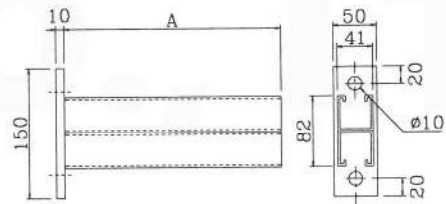
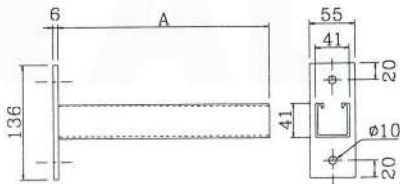
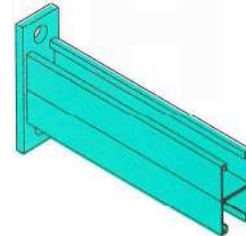
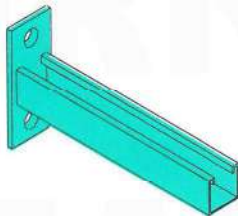

厚度 T=2mm

Units:mm

輕載型壁架 U-BRACKETS					重載型壁架 D-BRACKETS				
CAT.NO	W	A	材 質 MATERIAL	表面處理 FINISH	CAT.NO	W	A	材 質 MATERIAL	表面處理 FINISH
SWUH-01	100	200	鐵製(S) STEEL 不銹鋼製(4).(6) STAINLESS STEEL	(鐵)熱浸鍍鋅(H) 靜電粉體塗裝(P)	SDUH-06	600	700	鐵製(S) STEEL 不銹鋼製(4).(6) STAINLESS STEEL	(鐵)熱浸鍍鋅(H) 靜電粉體塗裝(P)
SWUH-02	200	300			SDUH-07	700	800		
SWUH-03	300	400			SDUH-08	800	900		
SWUH-04	400	500			SDUH-09	900	1000		
SWUH-05	500	600			SDUH-10	1000	1100		

## 線槽固定片 (HOLD DOWN CLAMP)

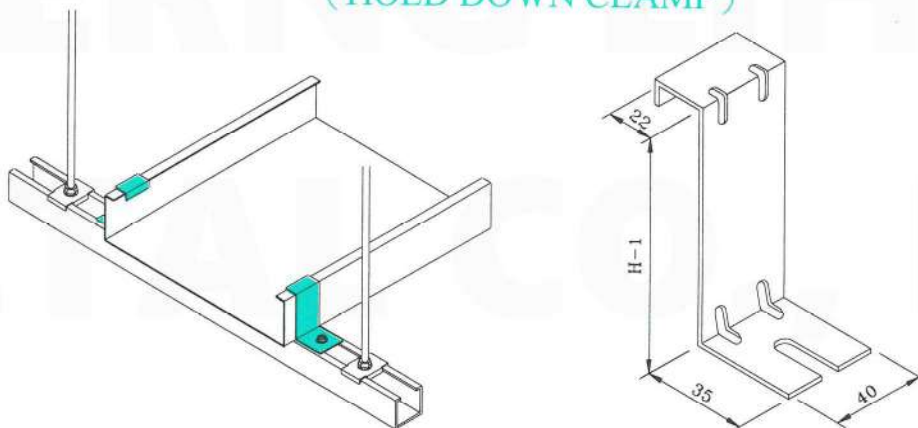

厚度 T=2mm

Units:mm

外側固定片 OUTSIDE HOLD DOWN CLAMP			
CAT.NO	H	材 質 MATERIAL	表面處理 FINISH
SHBAH	60	鐵製(S) STEEL 不銹鋼製(4).(6) STAINLESS STEEL	(鐵)熱浸鍍鋅(H) HOT DIP GALVANIZED 靜電粉體塗裝(P) POWDER COATING
SHBBH	80		
SHBCH	100		
SHBDH	120		
SHBEH	150		
SHBFH	200		
SHBGH	250		
SHBHH	300		

## 線槽分隔板 (STRAIGHT SEPARATOR)

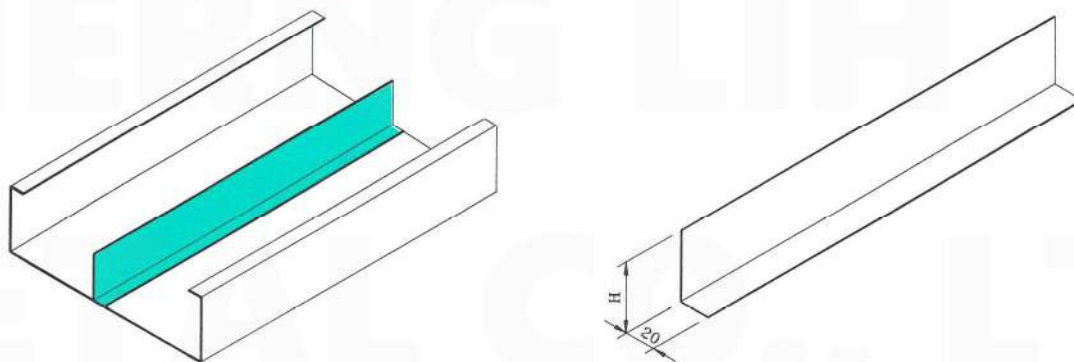

厚度 T 與線槽相同

Units:mm

直式分隔板 STRAIGHT SEPARATOR				
CAT.NO	H	L	材 質 MATERIAL	表面處理 FINISH
SCSAH	45	3000 (1500)	鋁合金(A) ALUMINUM ALLOY 鐵製(S) STEEL 不銹鋼製(4).(6) STAINLESS STEEL	(鋁)陽極處理(A) ANODIC OXIDATION (鐵)熱浸鍍鋅(H) HOT DIP GALVANIZED 靜電粉體塗裝(P) POWDER COATING
SCSBH	65			
SCSCH	85			
SCSDH	105			
SCSEH	135			
SCSFH	185			
SCSGH	235			
SCSHH	285			

## ” H ” 型 終 端 護 夾 ( H SHAP E GAP PROTECTORS )

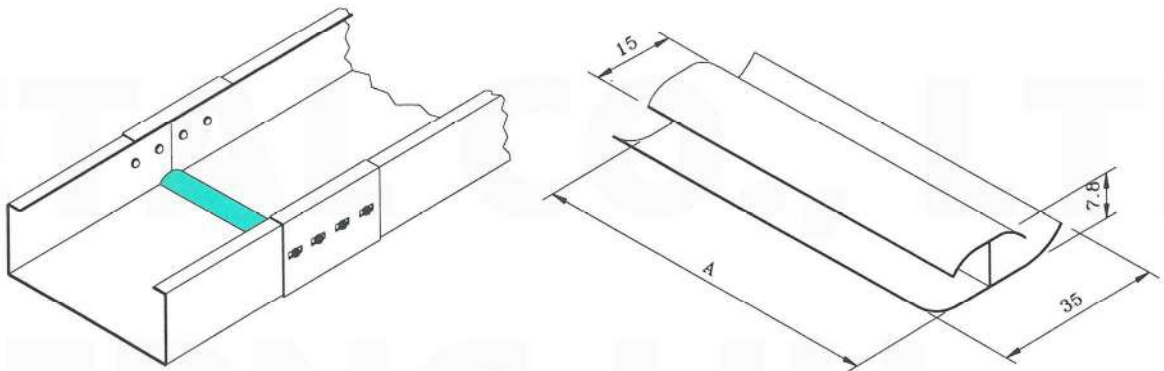

厚度 T=1.2mm

Units:mm

H 型 終 端 護 夾 H SHAP E GAP PROTECTORS				
CAT.NO	W	A	材 質 MATERIAL	表 面 處 理 FINISH
AGPA-01	100	94	鋁合金 AA6063T5 ALUMINUM ALLOY 6063T5	(鋁)陽極處理(A) ANODIC OXIDATION
AGPA-02	200	194		
AGPA-03	300	294		
AGPA-04	400	394		
AGPA-05	500	494		
AGPA-06	600	594		
AGPA-07	700	694		
AGPA-08	800	794		
AGPA-09	900	894		
AGPA-10	1000	994		



## (B 型)直式日光燈線槽 (STRAIGHT LENGTH CABLE RACEWAY)

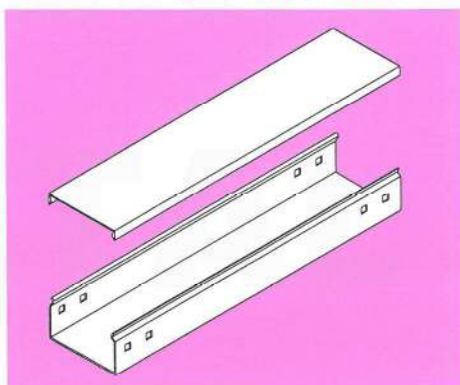

材 質：鋁合金 AA6063-T5 或 AA6063-T6  
表面處理：(鋁) 陽極處理(10 $\mu$ )

MATERIAL : ALUMINUM ALLOY AA6063-T5 OR AA6063-T6  
F I N I S H : ANODIC OXIDATION (10  $\mu$ )

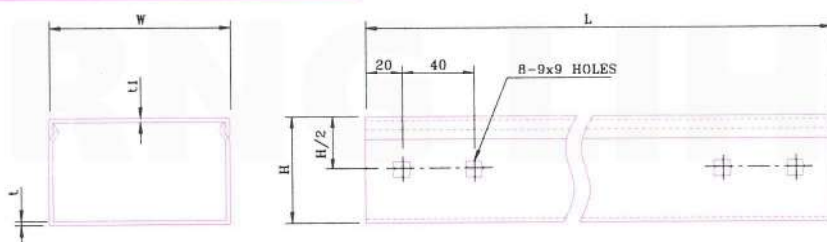

(Units:mm)

型 號 CAT.NO	線槽寬度 W	線槽高度 H	線槽厚度 t	蓋板厚度 t1	長 度 L
CLB7550S	75	50	2	2	3000
CLB10060S	100	60	1.6(2)	1.6(2)	
CLB15060S	150	60	2	2	
CLB20060S	200	60	2	2	

## (B 型)水平 90°日光燈線槽 (HORIZONTAL 90° )

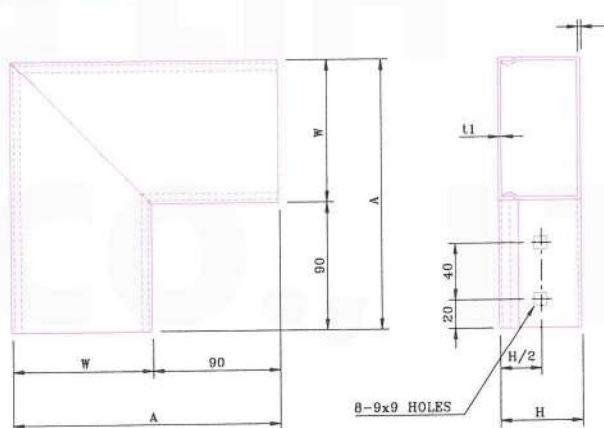
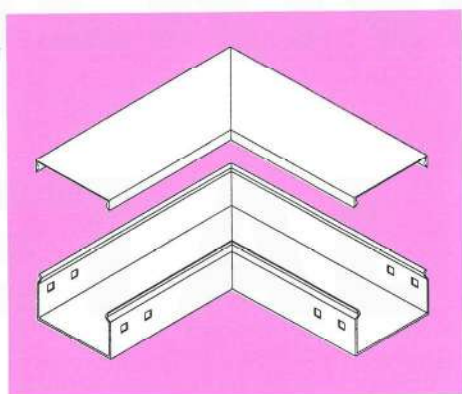

材 質：鋁合金 AA6063-T5 或 AA6063-T6  
表面處理：(鋁) 陽極處理(10 $\mu$ )

MATERIAL : ALUMINUM ALLOY AA6063-T5 OR AA6063-T6  
F I N I S H : ANODIC OXIDATION (10  $\mu$ )

(Units:mm)

型 號 CAT.NO	線槽寬度 W	線槽高度 H	線槽厚度 t	蓋板厚度 t1	長 度 A
CLB7550HL9	75	50	2	2	165
CLB10060HL9	100	60	1.6(2)	1.6(2)	190
CLB15060HL9	150	60	2	2	240
CLB20060HL9	200	60	2	2	290

## (B 型)水平 T 型日光燈線槽 (HORIZONTAL TEE)

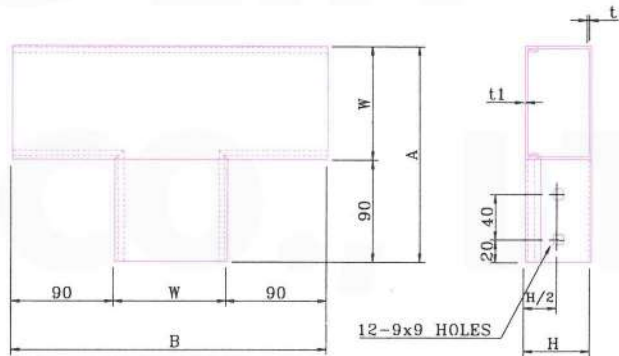
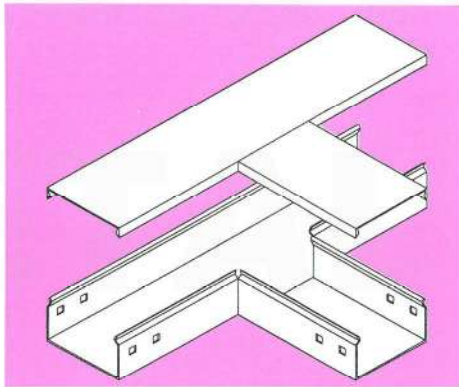

材 質：鋁合金 AA6063-T5 或 AA6063-T6  
表面處理：(鋁) 陽極處理(10 $\mu$ )

MATERIAL : ALUMINUM ALLOY AA6063-T5 OR AA6063-T6  
F I N I S H : ANODIC OXIDATION (10  $\mu$ )

(Units:mm)

型 號 CAT.NO	線槽寬度 W	線槽高度 H	線槽厚度 t	蓋板厚度 t1	長 度 A	長 度 B
CLB7550HT	75	50	2	2	165	255
CLB10060HT	100	60	1.6(2)	1.6(2)	190	280
CLB15060HT	150	60	2	2	240	330
CLB20060HT	200	60	2	2	290	380

## (B 型)水平 X 型日光燈線槽 (HORIZONTAL CROSS)

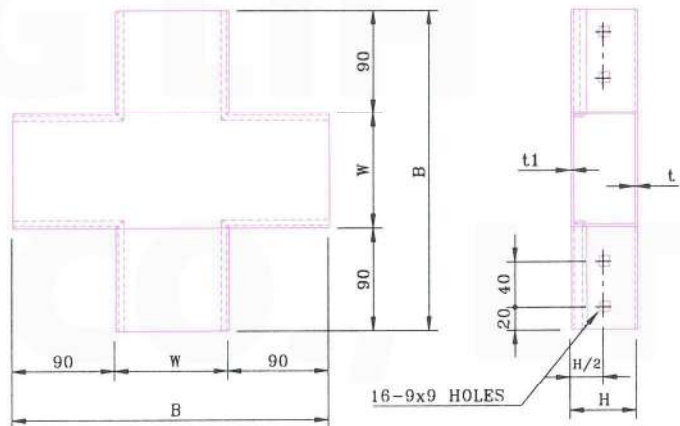
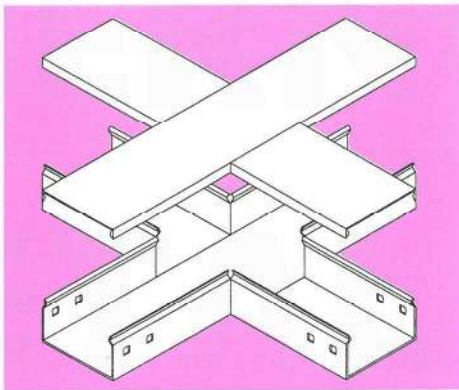

材 質：鋁合金 AA6063-T5 或 AA6063-T6  
表面處理：(鋁) 陽極處理(10 $\mu$ )

MATERIAL : ALUMINUM ALLOY AA6063-T5 OR AA6063-T6  
F I N I S H : ANODIC OXIDATION (10  $\mu$ )

(Units:mm)

型 號 CAT.NO	線槽寬度 W	線槽高度 H	線槽厚度 t	蓋板厚度 t1	長 度 B
CLB7550HX	75	50	2	2	255
CLB10060HX	100	60	1.6(2)	1.6(2)	280
CLB15060HX	150	60	2	2	330
CLB20060HX	200	60	2	2	380

## (B 型)垂直上升 90°日光燈線槽 (INSIDE VERTICAL 90°)

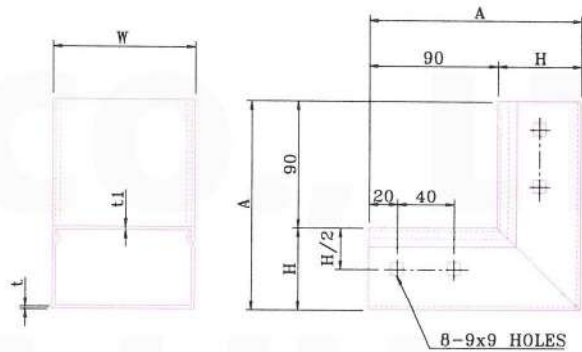
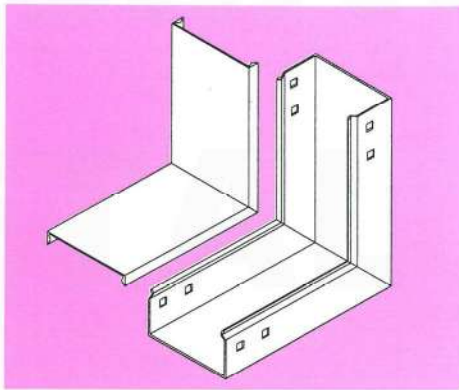

材 質：鋁合金 AA6063-T5 或 AA6063-T6  
表面處理：(鋁) 陽極處理(10 $\mu$ )

MATERIAL : ALUMINUM ALLOY AA6063-T5 OR AA6063-T6  
F I N I S H : ANODIC OXIDATION (10  $\mu$ )

(Units:mm)

型 號 CAT.NO	線槽寬度 W	線槽高度 H	線槽厚度 t	蓋板厚度 t1	長 度 A
CLB7550IV9	75	50	2	2	140
CLB10060IV9	100	60	1.6(2)	1.6(2)	150
CLB15060IV9	150	60	2	2	150
CLB20060IV9	200	60	2	2	150

## (B 型)垂直下降 90°日光燈線槽 (OUTSIDE VERTICAL 90°)

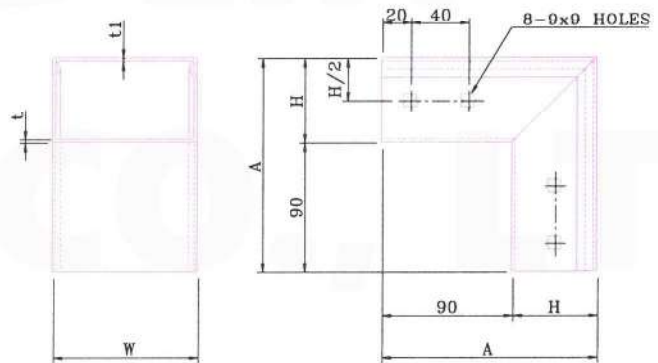
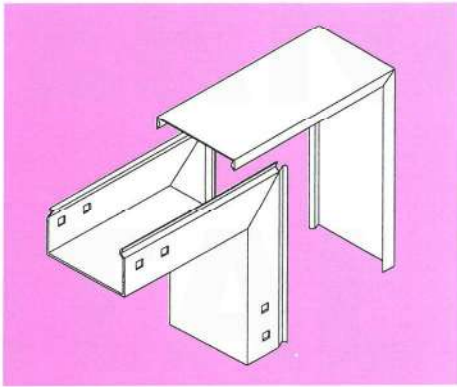

材 質：鋁合金 AA6063-T5 或 AA6063-T6  
表面處理：(鋁) 陽極處理(10 $\mu$ )

MATERIAL : ALUMINUM ALLOY AA6063-T5 OR AA6063-T6  
F I N I S H : ANODIC OXIDATION (10  $\mu$ )

(Units:mm)

型 號 CAT.NO	線槽寬度 W	線槽高度 H	線槽厚度 t	蓋板厚度 t1	長 度 B
CLB7550OV9	75	50	2	2	140
CLB10060OV9	100	60	1.6(2)	1.6(2)	150
CLB15060OV9	150	60	2	2	150
CLB20060OV9	200	60	2	2	150

# 日光燈線槽連接片 (STRAIGHT CONNECTOR)

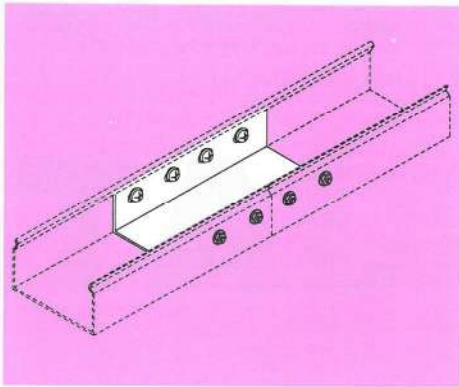

材 質：鋁合金 AA5052H32 或 AA1050H14  
表面處理：(鋁) 陽極處理(10 $\mu$ )

MATERIAL：ALUMINUM ALLOY AA5052H32  
ALUMINUM ALLOY AA1050H14  
F I N I S H：ANODIC OXIDATION (10 $\mu$ )

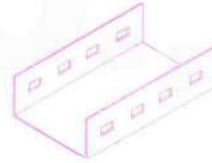

型 號 CAT.NO	
SCB7550U	
適用線槽	
75Wx50H	

(Units:mm)

型 號 CAT.NO	
SCB10060U	
適用線槽	
100Wx60H	

(Units:mm)

型 號 CAT.NO	
SCB15060U	
適用線槽	
150Wx60H	

(Units:mm)

型 號 CAT.NO	
SCB20060U	
適用線槽	
200Wx60H	

(Units:mm)

# 配電盤連接片 (PANNEL SPLICE PLATE)

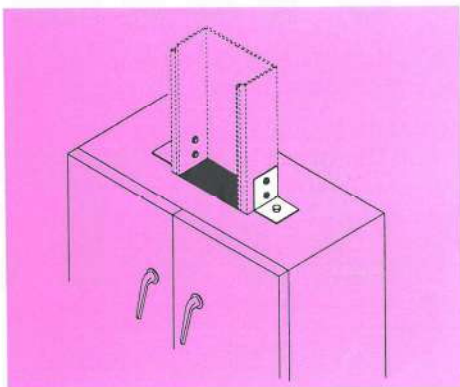

材 質：鋁合金 AA5052H32 或 AA1050H14  
表 面 處 理：(鋁) 陽極處理(10 $\mu$ )

MATERIAL : ALUMINUM ALLOY AA5052H32  
ALUMINUM ALLOY AA1050H14  
F I N I S H : ANODIC OXIDATION ( 10  $\mu$  )

(Units:mm)

型 號 CAT.NO	
PPB50L	
適用線槽	
75Wx50H	

(Units:mm)

型 號 CAT.NO	
PPB60L	
適用線槽	
100Wx60H	

(Units:mm)

型 號 CAT.NO	
PPB60L	
適用線槽	
150Wx60H	

(Units:mm)

型 號 CAT.NO	
PPB60L	
適用線槽	
200Wx60H	

# 終端封板 (BLIND END COVER)

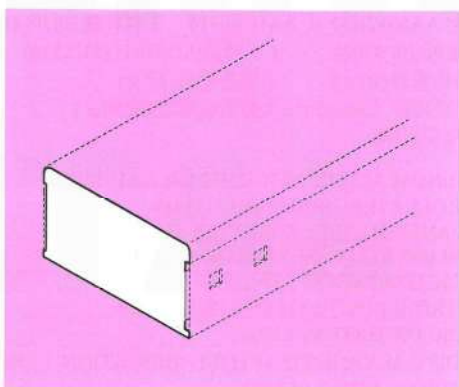

材 質：不銹鋼 SUS304

MATERIAL : STAINLESS STEEL 304

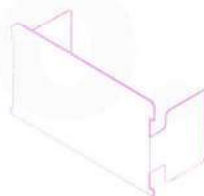

型 號 CAT.NO		(Units:mm)
BCB7550		
適用線槽		
75Wx50H		

型 號 CAT.NO		(Units:mm)
BCB10060		
適用線槽		
100Wx60H		

型 號 CAT.NO		(Units:mm)
BCB15060		
適用線槽		
150Wx60H		

型 號 CAT.NO		(Units:mm)
BCB20060		
適用線槽		
200Wx60H		

## (C 型)直式日光燈線槽 (STRAIGHT LENGTH CABLE RACEWAY)

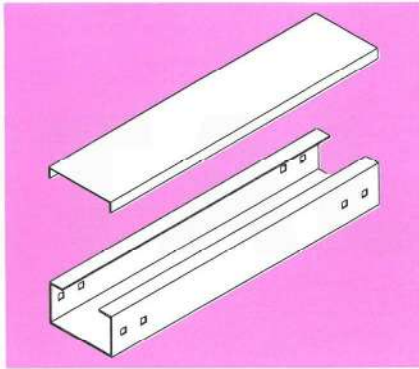

材 質：1.鋁合金 AA5052H32 或 AA1050H14 2.熱軋鐵板(JIS G3131)  
3.鍍鋅鐵板(JIS 3302) 4.不銹鋼(SUS304) (SUS316)  
表面處理：1.(鋁)陽極處理(10 $\mu$ ) 2.電著塗裝(17 $\mu$ )  
3.(鐵)熱浸鍍鋅 (350g/m<sup>2</sup>) 4.靜電粉體塗裝(50 $\mu$ )  
※其他特殊規格亦可接受訂購

MATERIAL: 1.ALUMINUM ALLOY AA5052H32 OR AA1050H14  
2.HOT ROLL STEEL SHEET (JIS G3131)  
3.GALVANIZED STEEL SHEET (JIS 3302)  
4.STAINLESS STEEL (SUS304).OR (SUS316)  
F I N I S H : 1.ANODIC OXIDATION ( 10  $\mu$  )  
2.ELECTRODEPOSITING COATING AFTER ANODIC OXIDATION ( 17  $\mu$  )  
3.HOT DIP GALVANIZED AFTER FABRICATION ( 350g/m<sup>2</sup> )  
4.POWDER COATING ( 50  $\mu$  )  
※OTHER SIZES(WIDTHS) CAN BE ORDERED

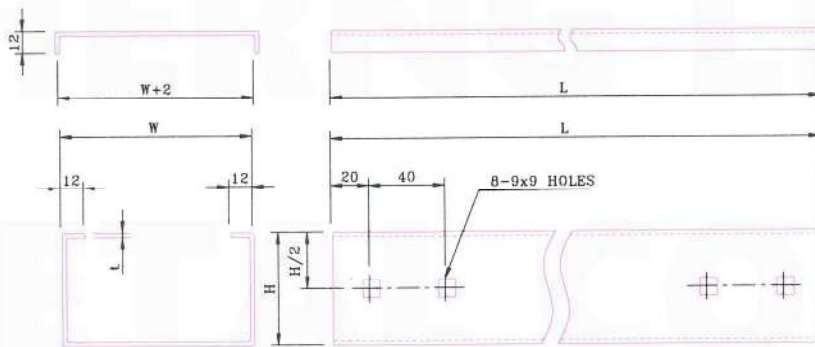

厚度(T)=2mm 或 1.6mm (Units:mm)

CAT.NO	W	H	L
CLC5045S	50	45	3000
CLC7550S	75	50	
CLC10050S	100	50	

## (C 型)水平 90°日光燈線槽 (HORIZONTAL 90° )

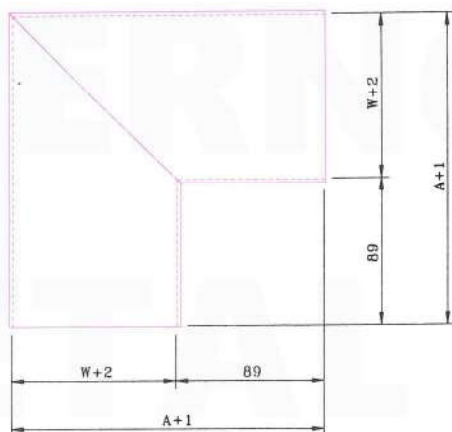
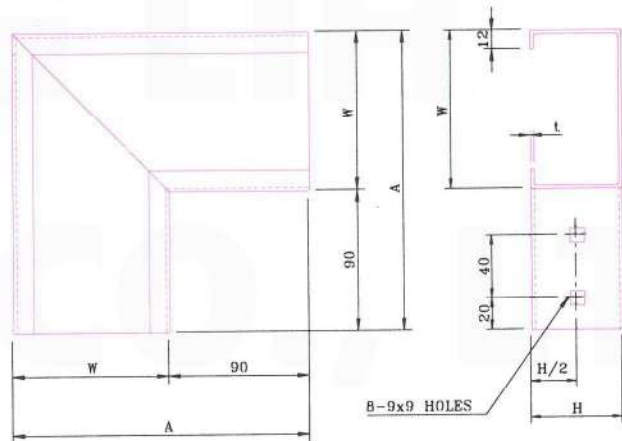
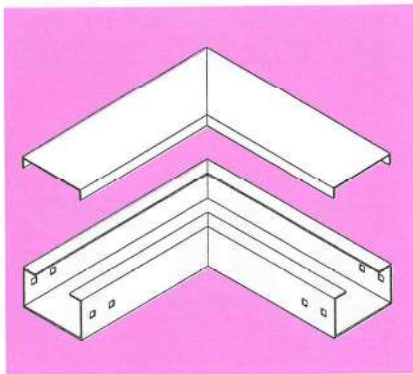

厚度(T)=2mm 或 1.6mm (Units:mm)

CAT.NO	W	H	A
CLC5045HL9	50	45	140
CLC7550HL9	75	50	165
CLC10050HL9	100	50	190

## (C 型)水平 T 型日光燈線槽 (HORIZONTAL TEE)

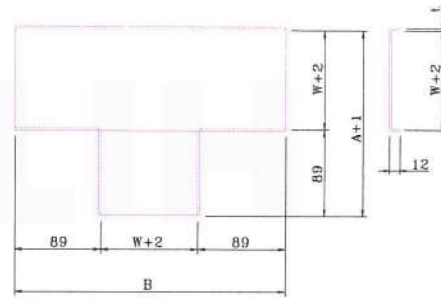
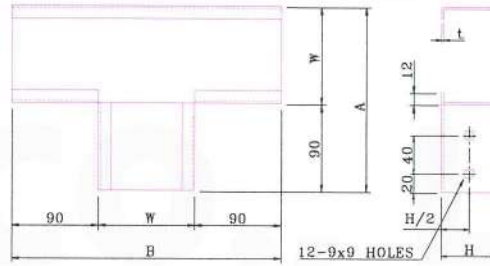
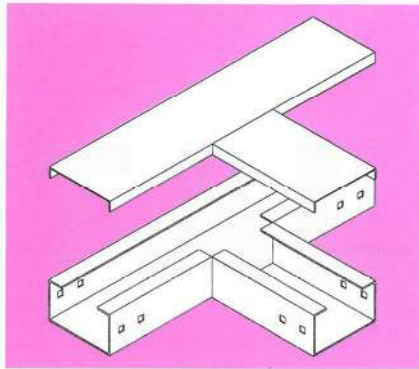

材 質：1.鋁合金 AA5052H32 或 AA1050H14  
 2.熱軋鐵板(JIS G3131) 3.鍍鋅鐵板(JIS 3302)  
 4.不銹鋼(SUS304)(SUS316)  
 表面處理：1.(鋁)陽極處理(10 $\mu$ ) 2.電著塗裝(17 $\mu$ )  
 3.(鐵)熱浸鍍鋅(350g/m<sup>2</sup>) 4.靜電粉體塗裝(50 $\mu$ )  
 ※其他特殊規格亦可接受訂購

MATERIAL：1.ALUMINUM ALLOY AA5052H32 OR AA1050H14  
 2.HOT ROLL STEEL SHEET (JIS G3131)  
 3.GALVANIZED STEEL SHEET (JIS 3302)  
 4.STAINLESS STEEL (SUS304).OR (SUS316)  
 FINISH：1.ANODIC OXIDATION (10 $\mu$ )  
 2.ELECTRODEPOSITING COATING AFTER  
 ANODIC OXIDATION (17 $\mu$ )  
 3.HOT DIP GALVANIZED AFTER  
 FABRICATION (350g/m<sup>2</sup>)  
 4.POWDER COATING (50 $\mu$ )  
 ※OTHER SIZES(WIDTHS) CAN BE ORDERED

厚度(T)=2mm 或 1.6mm (Units:mm)

CAT.NO	W	H	A	B
CLC5045HT	50	45	140	230
CLC7550HT	75	50	165	255
CLC10050HT	100	50	190	280

## (C 型)水平 X 型日光燈線槽 (HORIZONTAL CROSS)

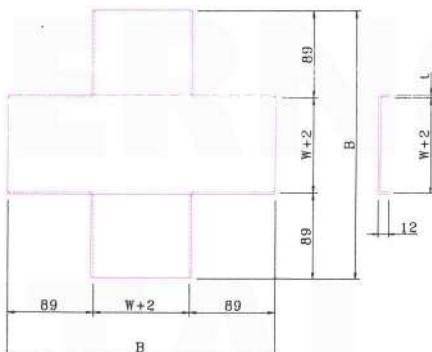
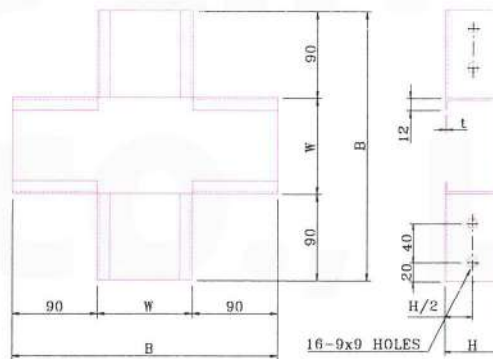
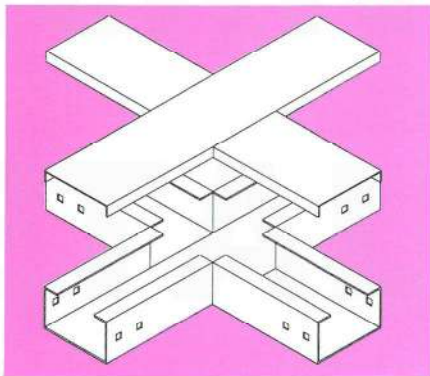

厚度(T)=2mm 或 1.6mm (Units:mm)

CAT.NO	W	H	B
CLC5045HX	50	45	230
CLC7550HX	75	50	255
CLC10050HX	100	50	280

## (C型)垂直上升 90°日光燈線槽 (INSIDE VERTICAL 90°)

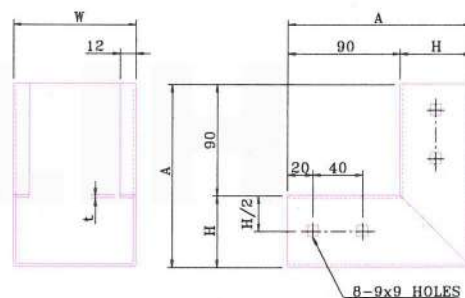
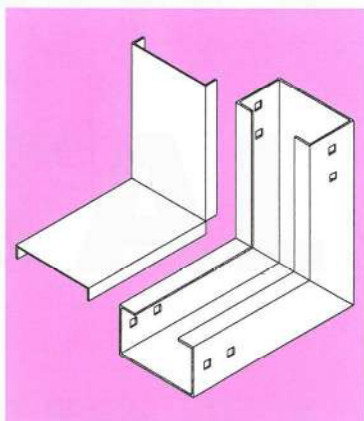

- 材 質：1.鋁合金 AA5052H32 或 AA1050H14  
 2.熱軋鐵板(JIS G3131) 3.鍍鋅鐵板(JIS 3302)  
 4.不銹鋼(SUS304) (SUS316)  
 表面處理：1.(鋁)陽極處理(10 $\mu$ ) 2.電著塗裝(17 $\mu$ )  
 3.(鐵)熱浸鍍鋅 (350g/m<sup>2</sup>) 4.靜電粉體塗裝(50 $\mu$ )  
 ※其他特殊規格亦可接受訂購

- MATERIAL：1.ALUMINUM ALLOY AA5052H32 OR AA1050H14  
 2.HOT ROLL STEEL SHEET (JIS G3131)  
 3.GALVANIZED STEEL SHEET (JIS 3302)  
 4.STAINLESS STEEL (SUS304).OR (SUS316)

- FINISH：1.ANODIC OXIDATION (10 $\mu$ )  
 2.ELECTRODEPOSITING COATING AFTER  
 ANODIC OXIDATION (17 $\mu$ )  
 3.HOT DIP GALVANIZED AFTER  
 FABRICATION (350g/m<sup>2</sup>)  
 4.POWDER COATING (50 $\mu$ )

※OTHER SIZES(WIDTHS) CAN BE ORDERED

厚度(T)=2mm 或 1.6mm (Units:mm)

CAT.NO	W	H	A
CLC5045IV9	50	45	135
CLC7550IV9	75	50	140
CLC10050IV9	100	50	140

## (C型)垂直下降 90°日光燈線槽 (OUTSIDE VERTICAL 90°)

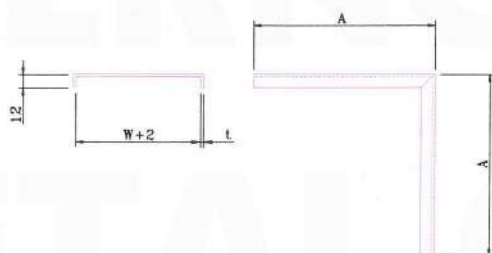
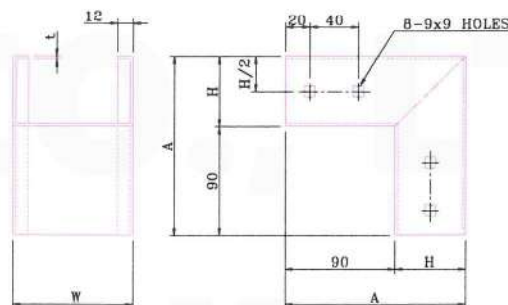
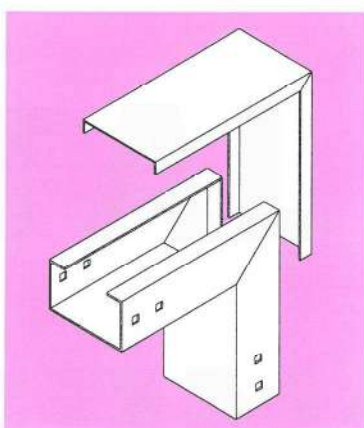

厚度(T)=2mm 或 1.6mm (Units:mm)

CAT.NO	W	H	A
CLC5045OV9	50	45	135
CLC7550OV9	75	50	140
CLC10050OV9	100	50	140

# 日光燈線槽連接片 (STRAIGHT CONNECTOR)

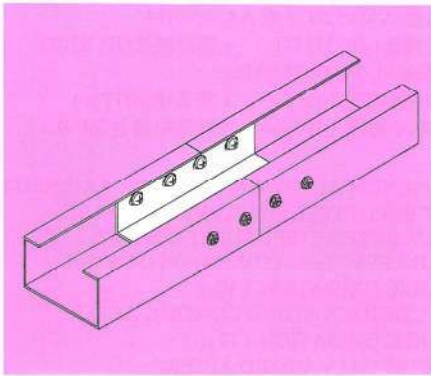

材 質：1. 鋁合金 AA5052H32 或 AA1050H14  
 2. 熱軋鐵板(JIS G3131) 3. 鍍鋅鐵板(JIS 3302)  
 4. 不銹鋼(SUS304) (SUS316)  
 表面處理：1. (鋁)陽極處理(10 $\mu$ ) 2. 電著塗裝(17 $\mu$ )  
 3. (鐵)熱浸鍍鋅 (350g/m<sup>2</sup>) 4. 靜電粉體塗裝(50 $\mu$ )

MATERIAL：1. ALUMINUM ALLOY AA5052H32 OR AA1050H14  
 2. HOT ROLL STEEL SHEET (JIS G3131)  
 3. GALVANIZED STEEL SHEET (JIS 3302)  
 4. STAINLESS STEEL (SUS304).OR (SUS316)

FINISH：1. ANODIC OXIDATION (10 $\mu$ )  
 2. ELECTRODEPOSITING COATING AFTER ANODIC OXIDATION (17 $\mu$ )  
 3. HOT DIP GALVANIZED AFTER FABRICATION (350g/m<sup>2</sup>)  
 4. POWDER COATING (50 $\mu$ )

(Units:mm)

型 號 CAT.NO	
SCC5045U	
適用線槽	
50Wx45H	

(Units:mm)

型 號 CAT.NO	
SCC7550U	
適用線槽	
75Wx50H	

(Units:mm)

型 號 CAT.NO	
SCC10050U	
適用線槽	
100Wx50H	

# 配電盤連接片 ( PANNEL SPLICE PLATE )

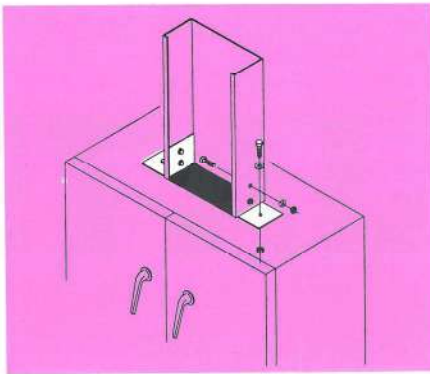

材 質 : 1.鋁合金 AA5052H32 或 AA1050H14  
 2.熱軋鐵板(JIS G3131) 3.鍍鋅鐵板(JIS 3302)  
 4.不銹鋼(SUS304) (SUS316)  
 表面處理 : 1.(鋁)陽極處理(10 $\mu$ ) 2.電著塗裝(17 $\mu$ )  
 3.(鐵)熱浸鍍鋅 (350g/m<sup>2</sup>) 4.靜電粉體塗裝(50 $\mu$ )

MATERIAL : 1.ALUMINUM ALLOY AA5052H32 OR AA1050H14  
 2.HOT ROLL STEEL SHEET (JIS G3131)  
 3.GALVANIZED STEEL SHEET (JIS 3302)  
 4.STAINLESS STEEL (SUS304).OR (SUS316)  
 FINISH : 1.ANODIC OXIDATION ( 10  $\mu$  )  
 2.ELECTRODEPOSITING COATING AFTER ANODIC OXIDATION ( 17  $\mu$  )  
 3.HOT DIP GALVANIZED AFTER FABRICATION ( 350g/m<sup>2</sup> )  
 4.POWDER COATING ( 50  $\mu$  )

(Units:mm)

型 號 CAT.NO	
PPC45L	
適用線槽	
50Wx45H	

(Units:mm)

型 號 CAT.NO	
PPC50L	
適用線槽	
75Wx50H	

(Units:mm)

型 號 CAT.NO	
PPC50L	
適用線槽	
100Wx50H	

# 終端封板 (BLIND END COVER)

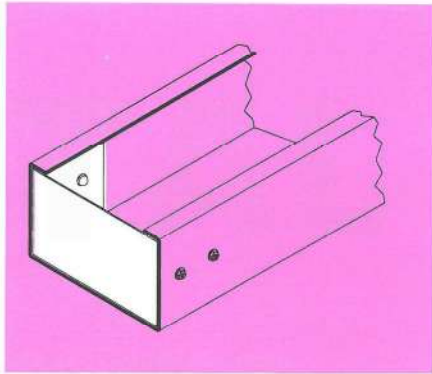

材 質：1.鋁合金 AA5052H32 或 AA1050H14  
 2.熱軋鐵板(JIS G3131) 3.鍍鋅鐵板(JIS 3302)  
 4.不銹鋼(SUS304) (SUS316)  
 表面處理：1.(鋁)陽極處理(10 $\mu$ ) 2.電著塗裝(17 $\mu$ )  
 3.(鐵)熱浸鍍鋅 (350g/m<sup>2</sup>) 4.靜電粉體塗裝(50 $\mu$ )

MATERIAL：1.ALUMINUM ALLOY AA5052H32 OR AA1050H14  
 2.HOT ROLL STEEL SHEET (JIS G3131)  
 3.GALVANIZED STEEL SHEET (JIS 3302)  
 4.STAINLESS STEEL (SUS304).OR (SUS316)  
 FINISH：1.ANODIC OXIDATION (10 $\mu$ )  
 2.ELECTRODEPOSITING COATING AFTER  
 ANODIC OXIDATION (17 $\mu$ )  
 3.HOT DIP GALVANIZED AFTER  
 FABRICATION (350g/m<sup>2</sup>)  
 4.POWDER COATING (50 $\mu$ )

(Units:mm)

型號 CAT.NO	
BCC5045	
適用線槽	
50Wx45H	

(Units:mm)

型號 CAT.NO	
BCC7550	
適用線槽	
75Wx50H	

(Units:mm)

型號 CAT.NO	
BCC10050	
適用線槽	
100Wx50H	

## 門型吊架 (RACEWAY HANGER)

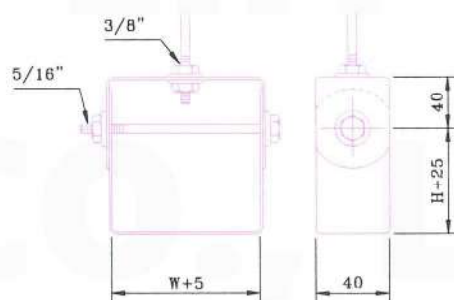
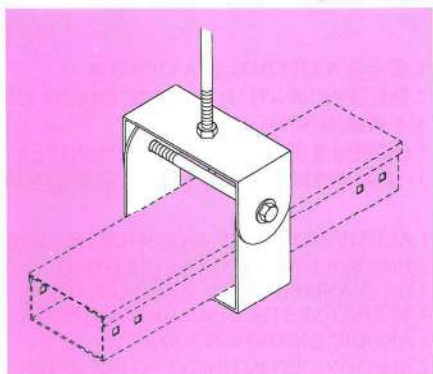

厚度 T=2mm

Units:mm

型號 CAT.NO	材質 MATERIAL	表面處理 FINISH
RHA	鐵製 STEEL 不銹鋼製 STAINLESS STEEL	(鐵)熱浸鍍鋅 HOT DIP GALVANIZED 靜電粉體塗裝 POWDER COATING

## 簡單型門型吊架 (RACEWAY HANGER)

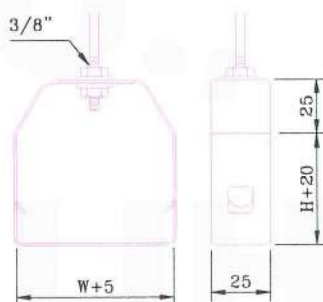
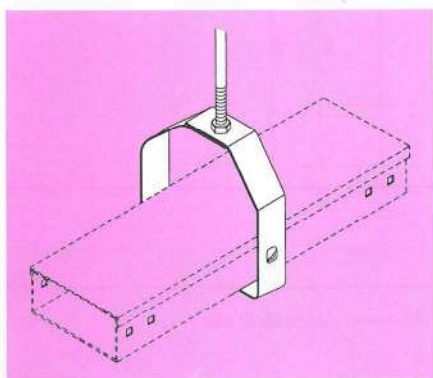

厚度 T=2mm

Units:mm

型號 CAT.NO	材質 MATERIAL	表面處理 FINISH
RHB	鐵製 STEEL 不銹鋼製 STAINLESS STEEL	(鐵)熱浸鍍鋅 HOT DIP GALVANIZED 靜電粉體塗裝 POWDER COATING

## 門型吊架安裝示意圖 (RACEWAY HANGER APPLICATION)

